

# LOCKING AND NON-LOCKING SHELF BRACKET INSTALLATION

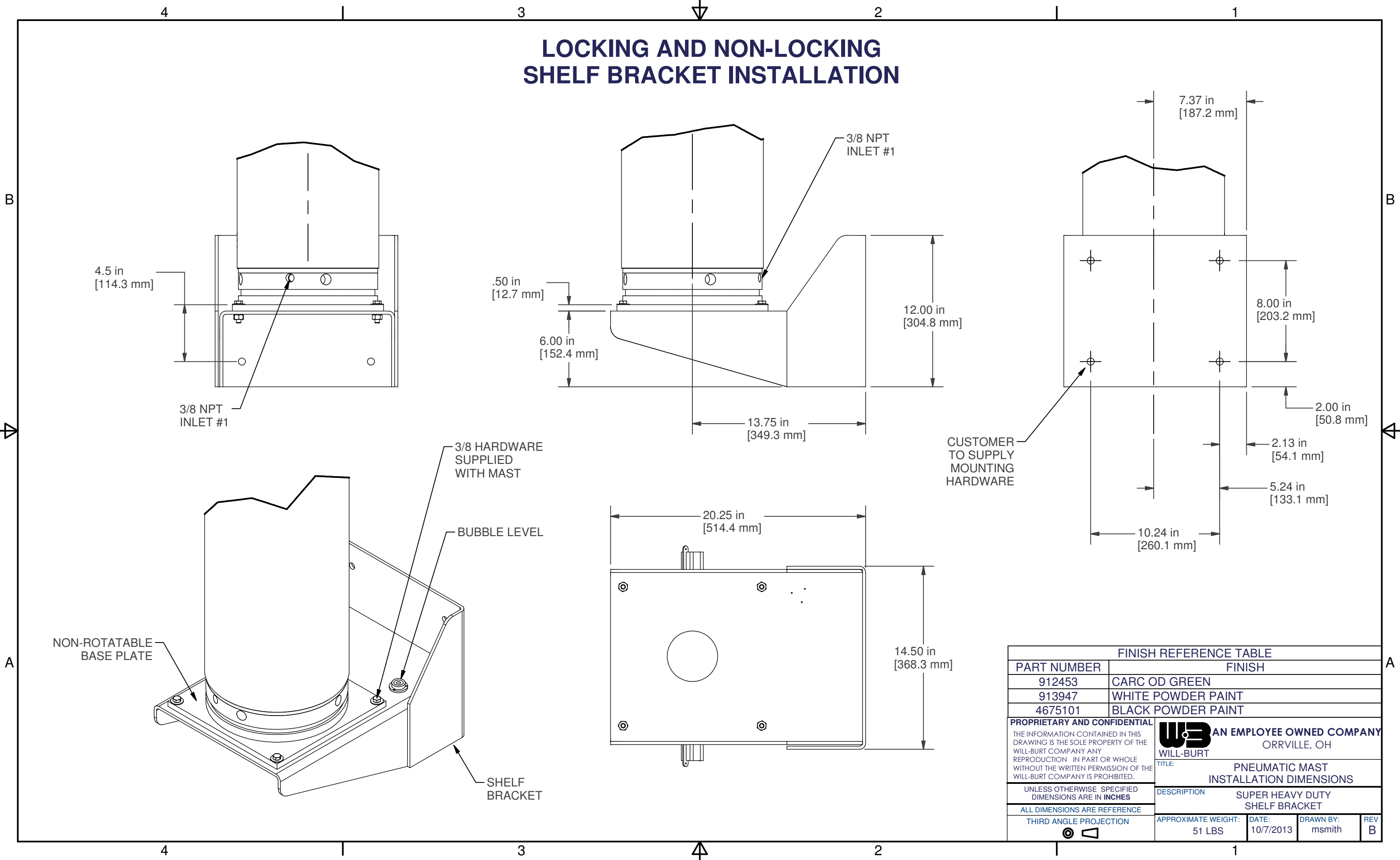

FINISH REFERENCE TABLE			
PART NUMBER	FINISH		
912453	CARC OD GREEN		
913947	WHITE POWDER PAINT		
4675101	BLACK POWDER PAINT		
<b>PROPRIETARY AND CONFIDENTIAL</b> THE INFORMATION CONTAINED IN THIS DRAWING IS THE SOLE PROPERTY OF THE WILL-BURT COMPANY ANY REPRODUCTION IN PART OR WHOLE WITHOUT THE WRITTEN PERMISSION OF THE WILL-BURT COMPANY IS PROHIBITED.		<b>AN EMPLOYEE OWNED COMPANY</b> ORRVILLE, OH	
UNLESS OTHERWISE SPECIFIED DIMENSIONS ARE IN INCHES		<b>TITLE:</b> PNEUMATIC MAST INSTALLATION DIMENSIONS	
ALL DIMENSIONS ARE REFERENCE		<b>DESCRIPTION</b> SUPER HEAVY DUTY SHELF BRACKET	
THIRD ANGLE PROJECTION		APPROXIMATE WEIGHT: 51 LBS	DATE: 10/7/2013
		DRAWN BY: msmith	REV B