

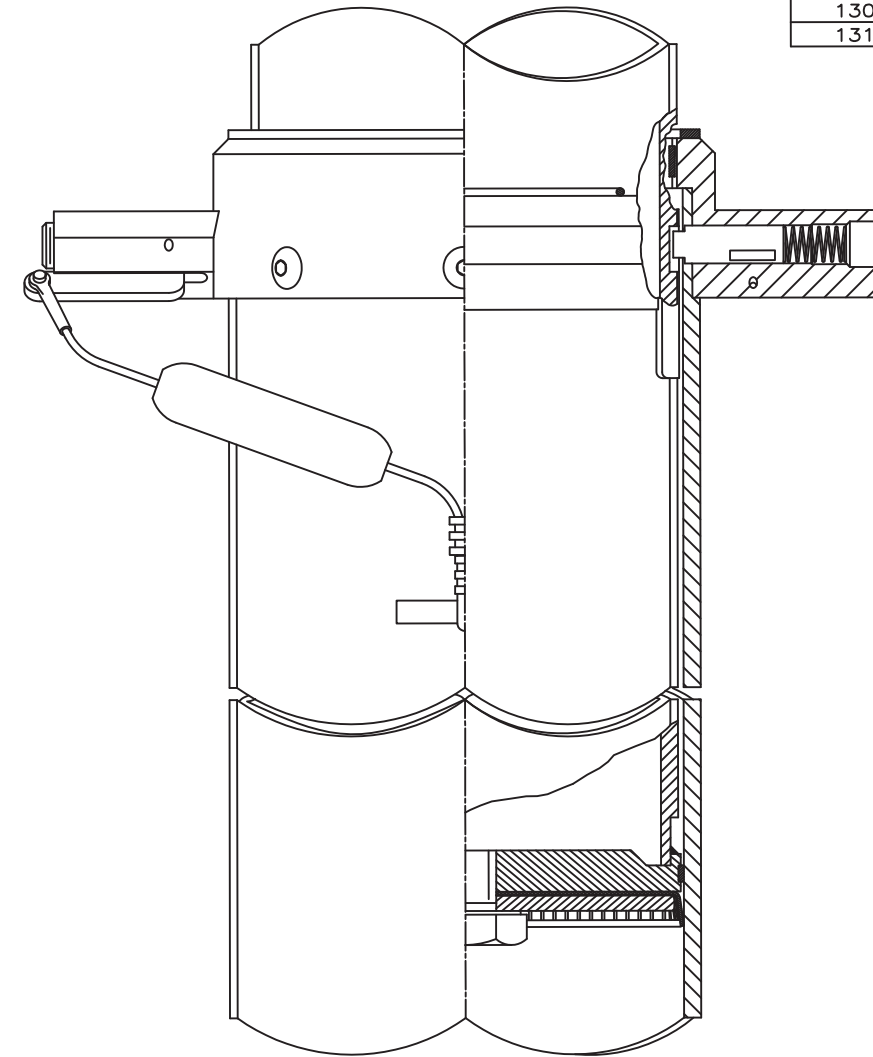

REVISIONS				
ECN	REV	DESCRIPTION	DATE	BY/APPVL
12525	A	SEE ECN	1-7-15	RRM/
12788	B	MOVED YOKES	7-2-15	RRM/
13066	C	MOVED YOKES IN VIEW	1-22-16	RRM/
13142	D	CHANGE LABEL KIT	3/11/16	MS/

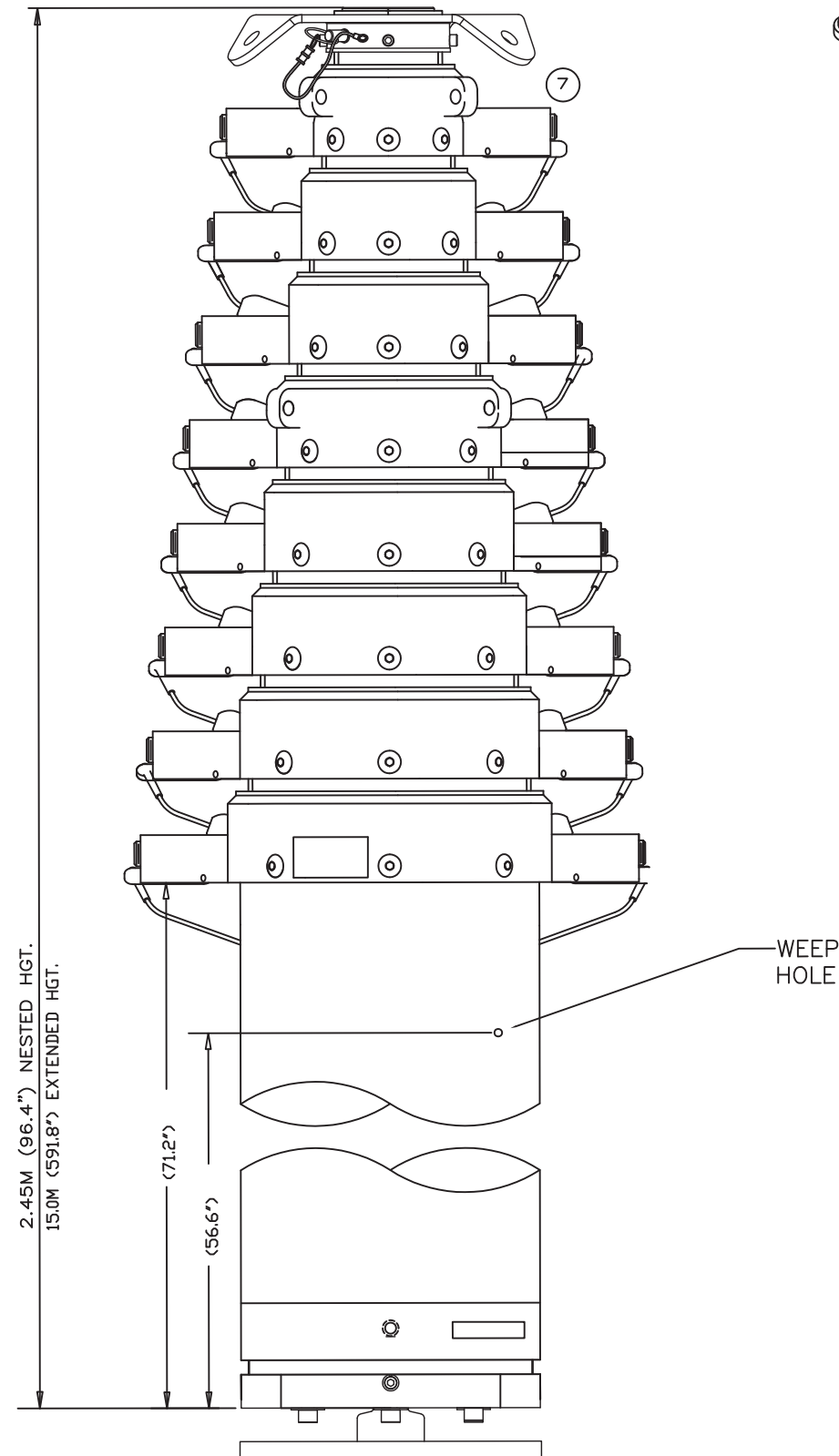

MATERIAL  SEE BOM ABOVE	UNLESS OTHERWISE SPECIFIED DIMENSIONS ARE IN INCHES  TOLERANCES ON: DECIMALS      ANGLES 0 = ±              ± 1/2" 00 = ±             ± 000 = ±           ±  FRACTIONS ±  BREAK ALL SHARP CORNERS 12° ON ALL MACHINED SURFACES	THIS DOCUMENT CONTAINS PROPRIETARY INFORMATION AND SHALL NOT BE USED OR REPRODUCED OR ITS CONTENTS DISCLOSED IN WHOLE OR IN PART, WITHOUT THE PRIOR WRITTEN CONSENT OF THE WILL-BURT COMPANY.		 AN EMPLOYEE OWNED COMPANY ORRVILLE, OHIO  NEXT ASS'Y DESC. SPECIAL PNEU MAST 2.4M-15M HDL  SIZE <b>B</b> DWG. No. 710491590 SCALE P/N 710491590 SHEET 1 OF 1
		SIGNATURE	DATE	
FINISH REF: BLACK HARDCOAT PER MIL-A-8625 TYPE III, CLASS 2		DR. BY RRM	9-10-14	
		CK. BY		
		APP. BY		