

VIEW A-A

REFERENCE APPLICATION INFORMATION
FITS STILETTO HD BASE TUBE Ø11.06
Ø1.25 INCH NYCOIL
OPTIONAL CLAMPS FOR Ø1 INCH NYCOIL

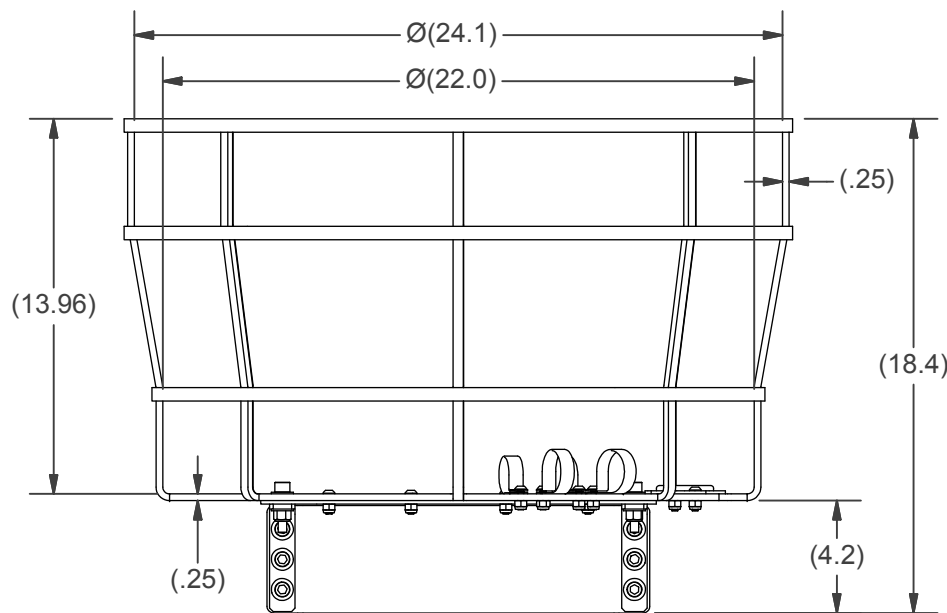

MATERIAL
(STEEL)

FINISH
(POWDER COAT
BLACK)

APPROX. WT:30.8 lbmass

THIRD ANGLE PROJECTION



UNLESS OTHERWISE SPECIFIED
DIMENSIONS ARE IN INCHES.
TOLERANCES ON DECIMALS ANGLES
0 = ± 0.030 ± 1/2°
00 = ± 0.010
000 = ± 0.005
FRACTIONAL ± 1/64"
1. ALL INSIDE EDGES TO HAVE
.005" TO .035" FILLETS.
2. ALL OUTSIDE EDGES TO HAVE
.005" TO .015" CHAMFER OR RADIUS.
125√ ON ALL MACHINED SURFACES

PROPRIETARY AND CONFIDENTIAL
THE INFORMATION CONTAINED IN THIS
DRAWING IS THE SOLE PROPERTY OF THE
WILL-BURT COMPANY ANY
REPRODUCTION IN PART OR WHOLE
WITHOUT THE WRITTEN PERMISSION OF
THE WILL-BURT COMPANY IS PROHIBITED.

APPROVALS	DATE
DRAWN CJY	2/1/2012
CHECKED	

WB AN EMPLOYEE OWNED COMPANY
WILL-BURT ORRVILLE, OH

TITLE NYCOIL BASKET HD STILETTO ASM			
SIZE B	DWG NO 47792	REV A	
PN: 4779201	SHEET 1 OF 2		