

REVISIONS				
ECN	REV	DESCRIPTION	DATE	BY/APPVL
10207	00	NEW	09-07-10	DJB/JDN

PANEL MOUNT (NFPA) ONLY

KIT 4236710

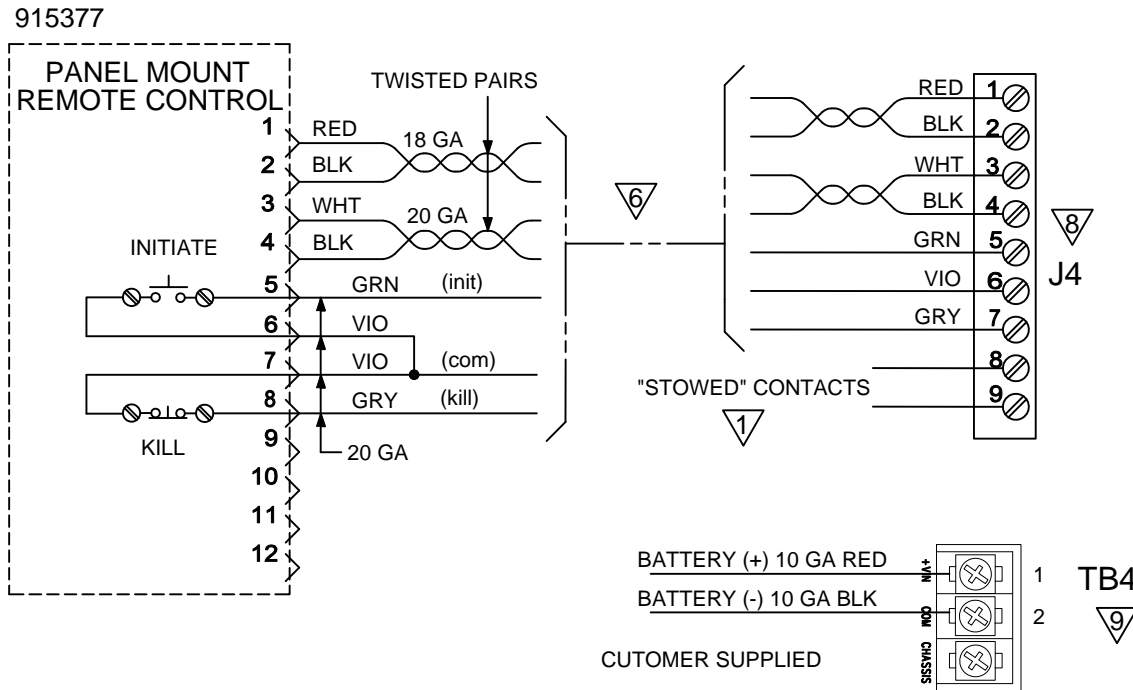

NOTES

- USE SW2 POSITION 1 ON BASE BOARD TO SELECT OPEN OR CLOSED WHEN NESTED.
(SOFTWARE 6.3 AND HIGHER)
SW2-1 OPEN = CONTACTS CLOSED WHEN NESTED
SW2-1 CLOSED = CONTACTS OPEN WHEN NESTED.
2 AMPS MAX CURRENT, 20 GA. MINIMUM CONDUCTOR.
- SW2 POSITION 2 ON BASE BOARD MUST BE OPEN (NFPA MODE)
- SW2 POSITION 2 ON BASE BOARD MUST BE CLOSED (STANDARD MODE)
- REMOVE JUMPER(S) IF REPLACED BY PARKING BRAKE INTERLOCK. G-H CLOSED WHEN BRAKE "ON".
AVAILABLE IN STANDARD MODE ONLY.
- VERTICAL: 4032502 (30 FT. CABLE), 4032503 (50 FT. CABLE)
ROOF-MOUNT: 4032505 (30 FT. CABLE), 4032506 (50 FT. CABLE)
- 4032101 (20 FT. CABLE), 4032102 (50 FT. CABLE)
- OPTIONAL DISABLE INPUT, CUSTOMER SUPPLIED CONTACTS. MUST HAVE CONTINUITY TO FUNCTION. WILL NOT ALLOW OPERATION IF OPEN, ACTS AS EMERGENCY STOP.
- 4.4in-lbs, 0.5Nm
- 20 in-lbs, 2.3Nm

AutoCAD Drawing: NS J-Box Wiring.DWG	UNLESS OTHERWISE SPECIFIED DIMENSIONS ARE IN INCHES TOLERANCES ON: DECIMALS ANGLES 0 = ± .12" 00 = ± .005" 000 = ± .001" FRACTIONS ± BREAK ALL SHARP CORNERS 1/32" ON ALL MACHINED SURFACES	THIS DOCUMENT CONTAINS PROPRIETARY INFORMATION AND SHALL NOT BE USED OR REPRODUCED OR ITS CONTENTS DISCLOSED IN WHOLE OR IN PART, WITHOUT THE PRIOR WRITTEN CONSENT OF THE WILL-BURT COMPANY. FOR LOGISTICAL SUPPORT ONLY SIGNATURE DATE DR. BY DJB - CK. BY JDN - APP. BY	WILL-BURT AN EMPLOYEE OWNED COMPANY ORRVILLE, OHIO NEXT ASSY DESC. NIGHTSCAN CHIEF ROOF-MOUNT NFPA SINGLE HARD-WIRED PANEL MOUNT SIZE DWG. No. B WD-72001 SCALE NTS SHEET 1 OF 1
--	--	--	---

REVISIONS				
ECN	REV	DESCRIPTION	DATE	BY/APPVL
10207	00	NEW	09-07-10	DJB/JDN

NFPA J-BOX
KIT 4236705

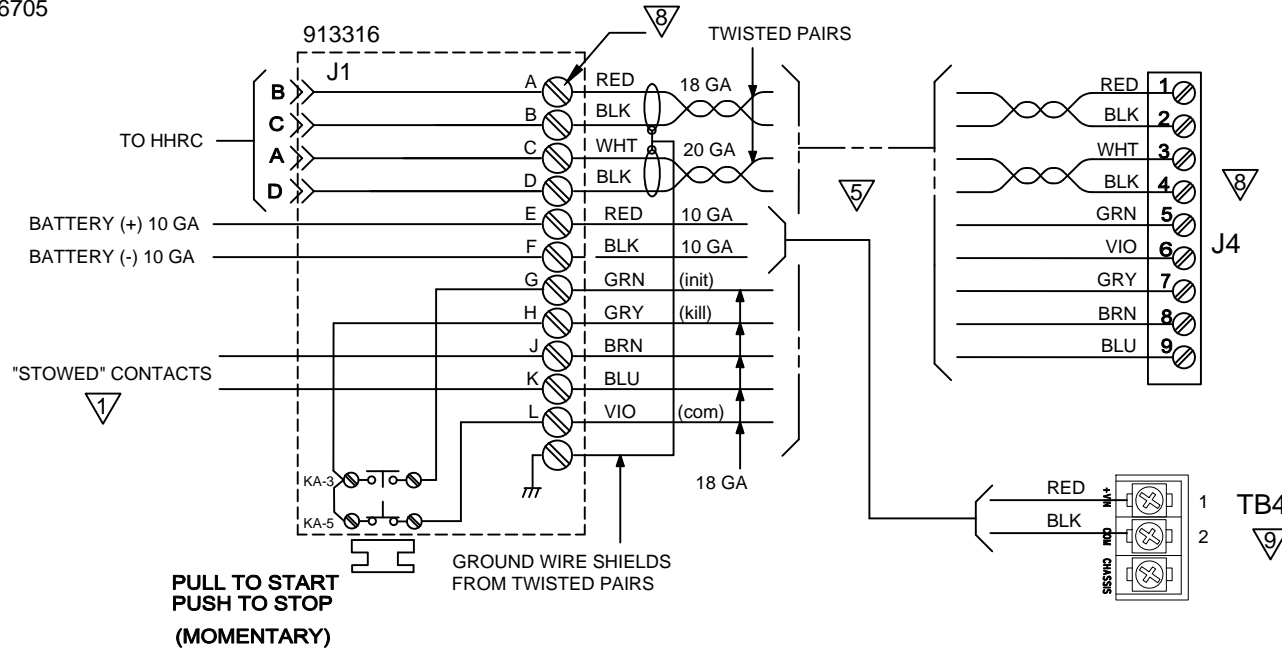

NOTES

- USE SW2 POSITION 1 ON BASE BOARD TO SELECT OPEN OR CLOSED WHEN NESTED.
(SOFTWARE 6.3 AND HIGHER)
SW2-1 OPEN = CONTACTS CLOSED WHEN NESTED
SW2-1 CLOSED = CONTACTS OPEN WHEN NESTED.
2 AMPS MAX CURRENT, 20 GA. MINIMUM CONDUCTOR.
- SW2 POSITION 2 ON BASE BOARD MUST BE OPEN (NFPA MODE)
- SW2 POSITION 2 ON BASE BOARD MUST BE CLOSED (STANDARD MODE)
- REMOVE JUMPER(S) IF REPLACED BY PARKING BRAKE INTERLOCK. G-H CLOSED WHEN BRAKE "ON".
AVAILABLE IN STANDARD MODE ONLY.
- VERTICAL: 4032502 (30 FT. CABLE), 4032503 (50 FT. CABLE)
ROOF-MOUNT: 4032505 (30 FT. CABLE), 4032506 (50 FT. CABLE)
- 4032101 (20 FT. CABLE), 4032102 (50 FT. CABLE)
- OPTIONAL DISABLE INPUT, CUSTOMER SUPPLIED CONTACTS. MUST HAVE CONTINUITY TO FUNCTION. WILL NOT ALLOW OPERATION IF OPEN, ACTS AS EMERGENCY STOP.
- 4.4in-lbs, 0.5Nm
- 20 in-lbs, 2.3Nm

AutoCAD Drawing: NS J-Box Wiring.DWG	UNLESS OTHERWISE SPECIFIED DIMENSIONS ARE IN INCHES TOLERANCES ON: DECIMALS ANGLES 0 = ± ± 1/2" 00 = ± 000 = ± FRACTIONS ± BREAK ALL SHARP CORNERS 1/32" ON ALL MACHINED SURFACES	THIS DOCUMENT CONTAINS PROPRIETARY INFORMATION AND SHALL NOT BE USED OR REPRODUCED OR ITS CONTENTS DISCLOSED IN WHOLE OR IN PART, WITHOUT THE PRIOR WRITTEN CONSENT OF THE WILL-BURT COMPANY. FOR LOGISTICAL SUPPORT ONLY SIGNATURE DATE DR. BY DJB - CK. BY JDN - APP. BY	 WILL BURT AN EMPLOYEE OWNED COMPANY ORRVILLE, OHIO NEXT ASSY DESC. NIGHTSCAN CHIEF ROOF-MOUNT NFPA SINGLE HARD-WIRED J-BOX SIZE B DWG. No. WD-72002 SCALE NTS SHEET 1 OF 1
--	---	--	--

REVISIONS				
ECN	REV	DESCRIPTION	DATE	BY/APPVL
10207	00	NEW	09-07-10	DJB/JDN

STANDARD J-BOX 3

KIT 4236704

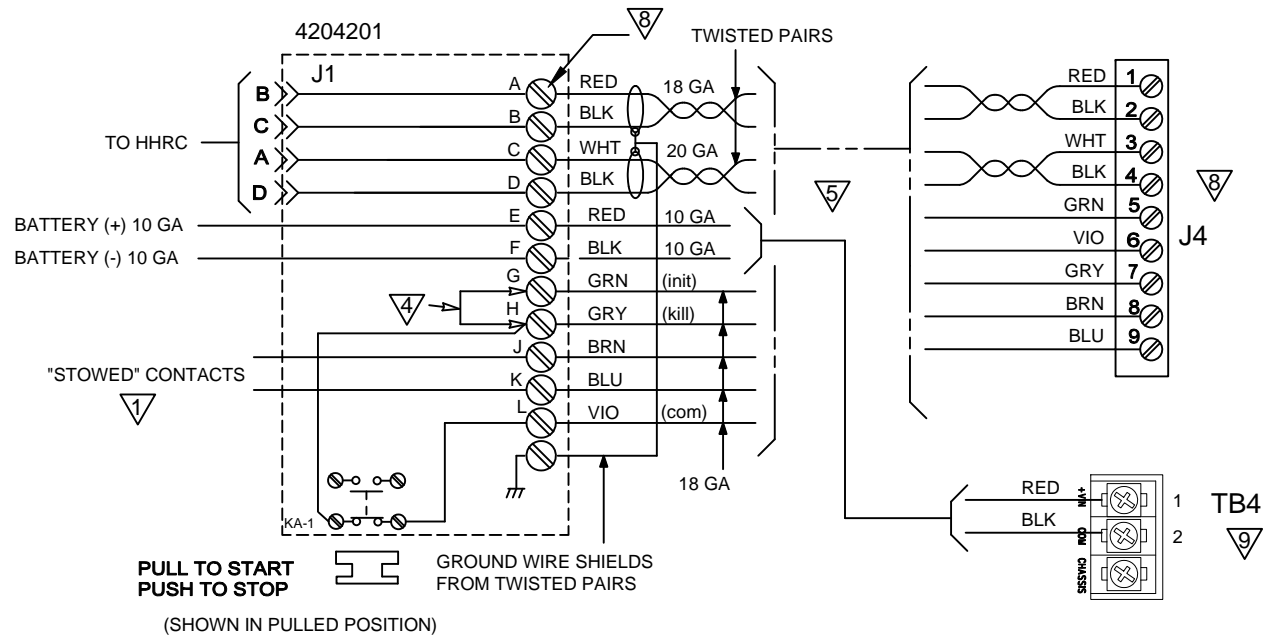

NOTES

- USE SW2 POSITION 1 ON BASE BOARD TO SELECT OPEN OR CLOSED WHEN NESTED.
(SOFTWARE 6.3 AND HIGHER)
SW2-1 OPEN = CONTACTS CLOSED WHEN NESTED
SW2-1 CLOSED = CONTACTS OPEN WHEN NESTED.
2 AMPS MAX CURRENT, 20 GA. MINIMUM CONDUCTOR.
- SW2 POSITION 2 ON BASE BOARD MUST BE OPEN (NFPA MODE)
- SW2 POSITION 2 ON BASE BOARD MUST BE CLOSED (STANDARD MODE)
- REMOVE JUMPER(S) IF REPLACED BY PARKING BRAKE INTERLOCK. G-H CLOSED WHEN BRAKE "ON".
AVAILABLE IN STANDARD MODE ONLY.
- VERTICAL: 4032502 (30 FT. CABLE), 4032503 (50 FT. CABLE)
ROOF-MOUNT: 4032505 (30 FT. CABLE), 4032506 (50 FT. CABLE)
- 4032101 (20 FT. CABLE), 4032102 (50 FT. CABLE)
- OPTIONAL DISABLE INPUT, CUSTOMER SUPPLIED CONTACTS. MUST HAVE CONTINUITY TO FUNCTION. WILL NOT ALLOW OPERATION IF OPEN, ACTS AS EMERGENCY STOP.
- 4.4in-lbs, 0.5Nm
- 20 in-lbs, 2.3Nm

AutoCAD Drawing: NS J-Box Wiring.DWG	UNLESS OTHERWISE SPECIFIED DIMENSIONS ARE IN INCHES TOLERANCES ON: DECIMALS ANGLES 0 = ± ± 1/2" 00 = ± ± 000 = ± ± FRACTIONS ± BREAK ALL SHARP CORNERS 1/32" ON ALL MACHINED SURFACES	THIS DOCUMENT CONTAINS PROPRIETARY INFORMATION AND SHALL NOT BE USED OR REPRODUCED OR ITS CONTENTS DISCLOSED IN WHOLE OR IN PART, WITHOUT THE PRIOR WRITTEN CONSENT OF THE WILL-BURT COMPANY. FOR LOGISTICAL SUPPORT ONLY SIGNATURE DATE DR.BY DJB - CK.BY JDN - APP.BY	WILL-BURT AN EMPLOYEE OWNED COMPANY ORRVILLE, OHIO NEXT ASSY DESC. NIGHTSCAN CHIEF ROOF-MOUNT STANDARD SINGLE HARD-WIRED J-BOX SIZE B DWG. No. WD-72003 SCALE NTS SHEET 1 OF 1
--	--	---	---

REVISIONS				
ECN	REV	DESCRIPTION	DATE	BY/APPVL
10207	00	NEW	09-07-10	DJB/JDN

(2) NFPA J-BOXES

KIT 4236711

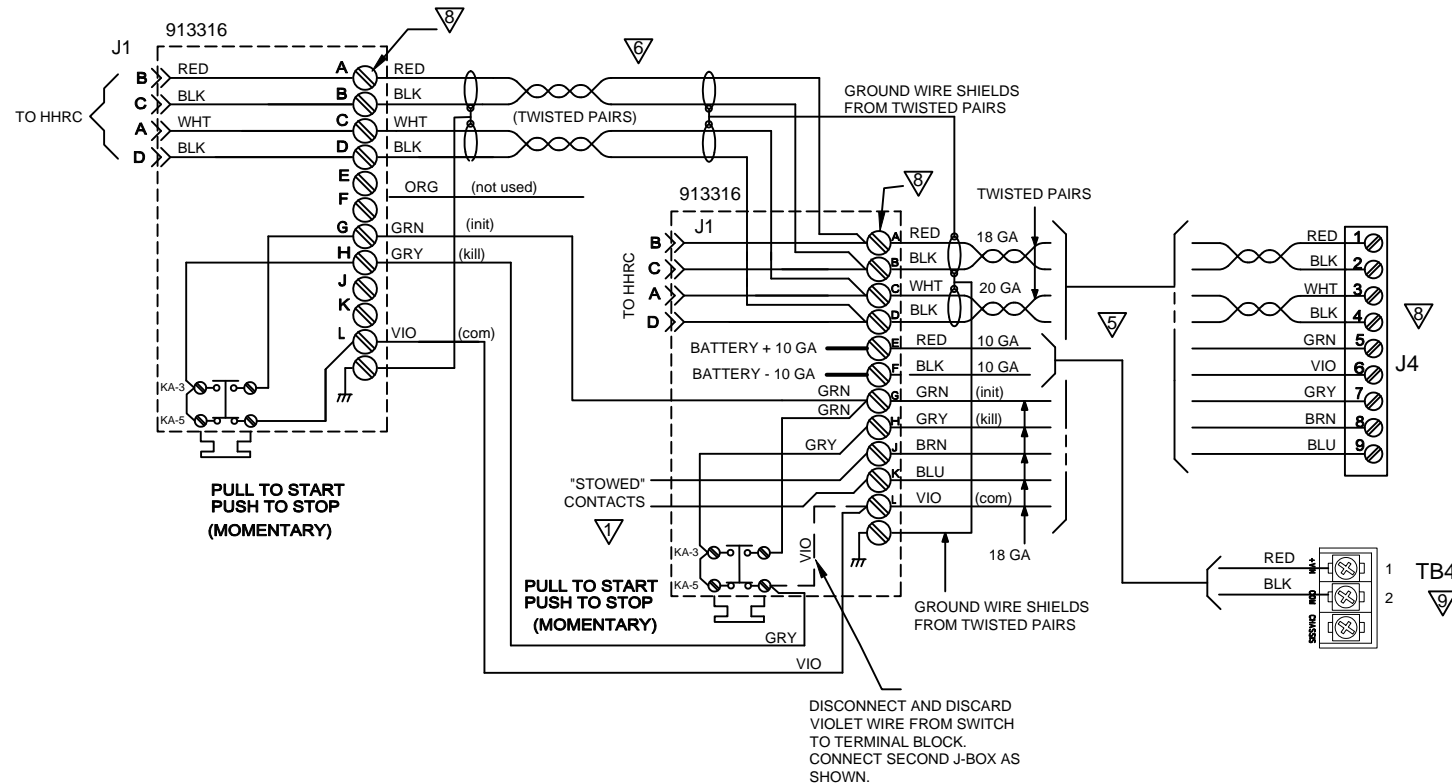

NOTES

- USE SW2 POSITION 1 ON BASE BOARD TO SELECT OPEN OR CLOSED WHEN NESTED.
(SOFTWARE 6.3 AND HIGHER)
SW2-1 OPEN = CONTACTS CLOSED WHEN NESTED
SW2-1 CLOSED = CONTACTS OPEN WHEN NESTED.
2 AMPS MAX CURRENT, 20 GA. MINIMUM CONDUCTOR.
- SW2 POSITION 2 ON BASE BOARD MUST BE OPEN (NFPA MODE)
- SW2 POSITION 2 ON BASE BOARD MUST BE CLOSED (STANDARD MODE)
- REMOVE JUMPER(S) IF REPLACED BY PARKING BRAKE INTERLOCK. G-H CLOSED WHEN BRAKE "ON".
AVAILABLE IN STANDARD MODE ONLY.
- VERTICAL: 4032502 (30 FT. CABLE), 4032503 (50 FT. CABLE)
ROOF-MOUNT: 4032505 (30 FT. CABLE), 4032506 (50 FT. CABLE)
- 4032101 (20 FT. CABLE), 4032102 (50 FT. CABLE)
- OPTIONAL DISABLE INPUT, CUSTOMER SUPPLIED CONTACTS. MUST HAVE CONTINUITY TO FUNCTION. WILL NOT ALLOW OPERATION IF OPEN, ACTS AS EMERGENCY STOP.
- 4.4in-lbs, 0.5Nm
- 20 in-lbs, 2.3Nm

AutoCAD Drawing: NS J-Box Wiring.DWG	UNLESS OTHERWISE SPECIFIED DIMENSIONS ARE IN INCHES	THIS DOCUMENT CONTAINS PROPRIETARY INFORMATION AND SHALL NOT BE USED OR REPRODUCED OR ITS CONTENTS DISCLOSED IN WHOLE OR IN PART, WITHOUT THE PRIOR WRITTEN CONSENT OF THE WILL-BURT COMPANY. FOR LOGISTICAL SUPPORT ONLY	AN EMPLOYEE OWNED COMPANY ORRVILLE, OHIO
	TOLERANCES ON: DECIMALS ANGLES D = ± 00 = ± 000 = ±		
FINISH	FRACTIONS ±	SIGNATURE	DATE
	BREAK ALL SHARP CORNERS 1/32" ON ALL MACHINED SURFACES	DR. BY DJB	-
		CK. BY JDN	-
		APP. BY	-
		SIZE B	DWG. No. WD-72005
		SCALE NTS	SHEET 1 OF 1

REVISIONS				
ECN	REV	DESCRIPTION	DATE	BY/APPVL
10207	00	NEW	09-07-10	DJB/JDN

(2) STANDARD J-BOXES 3

KIT 4236712

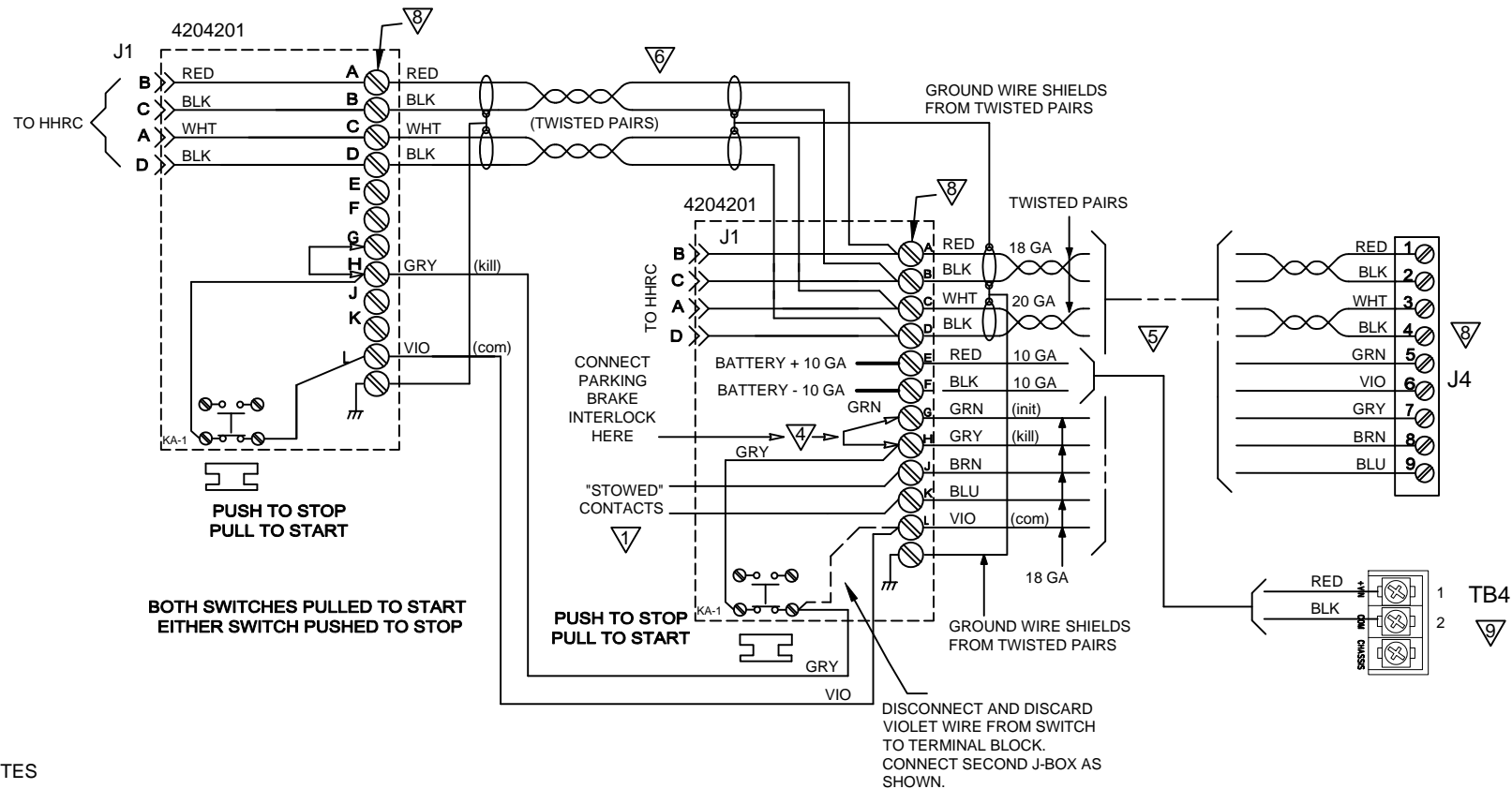

NOTES

- USE SW2 POSITION 1 ON BASE BOARD TO SELECT OPEN OR CLOSED WHEN NESTED.
(SOFTWARE 6.3 AND HIGHER)
SW2-1 OPEN = CONTACTS CLOSED WHEN NESTED
SW2-1 CLOSED = CONTACTS OPEN WHEN NESTED.
2 AMPS MAX CURRENT, 20 GA. MINIMUM CONDUCTOR.
- SW2 POSITION 2 ON BASE BOARD MUST BE OPEN (NFPA MODE)
- SW2 POSITION 2 ON BASE BOARD MUST BE CLOSED (STANDARD MODE)
- REMOVE JUMPER(S) IF REPLACED BY PARKING BRAKE INTERLOCK. G-H CLOSED WHEN BRAKE "ON".
AVAILABLE IN STANDARD MODE ONLY.
- VERTICAL: 4032502 (30 FT. CABLE), 4032503 (50 FT. CABLE)
ROOF-MOUNT: 4032505 (30 FT. CABLE), 4032506 (50 FT. CABLE)
- 4032101 (20 FT. CABLE), 4032102 (50 FT. CABLE)
- OPTIONAL DISABLE INPUT, CUSTOMER SUPPLIED CONTACTS. MUST HAVE CONTINUITY TO FUNCTION. WILL NOT ALLOW OPERATION IF OPEN, ACTS AS EMERGENCY STOP.
- 4.4in-lbs, 0.5Nm
- 20 in-lbs, 2.3Nm

AutoCAD Drawing: NS J-Box Wiring.DWG	UNLESS OTHERWISE SPECIFIED DIMENSIONS ARE IN INCHES	THIS DOCUMENT CONTAINS PROPRIETARY INFORMATION AND SHALL NOT BE USED OR REPRODUCED OR ITS CONTENTS DISCLOSED IN WHOLE OR IN PART, WITHOUT THE PRIOR WRITTEN CONSENT OF THE WILL-BURT COMPANY. FOR LOGISTICAL SUPPORT ONLY	AN EMPLOYEE OWNED COMPANY ORRVILLE, OHIO
	TOLERANCES ON: DECIMALS ANGLES 0 = ± ± 1/2" 00 = ± 000 = ± FRACTIONS ±		
FINISH	BREAK ALL SHARP CORNERS 1/32" ON ALL MACHINED SURFACES	SIGNATURE DATE DR. BY DJB - CK. BY JDN - APP. BY	SIZE DWG. No. WD-72006 SCALE NTS SHEET 1 OF 1

REVISIONS				
ECN	REV	DESCRIPTION	DATE	BY/APPVL
10207	00	NEW	09-07-10	DJB/JDN
10840	A	ADD WIRING DETAILS FOR NO E-STOP	12-19-11	DJB/JMK
11550	B	CABLE PART NUMBER RANGE EXPANDED.	03-29-13	DJB/JA

WIRELESS WITH STANDARD E-STOP

KIT 4362103



STANDARD

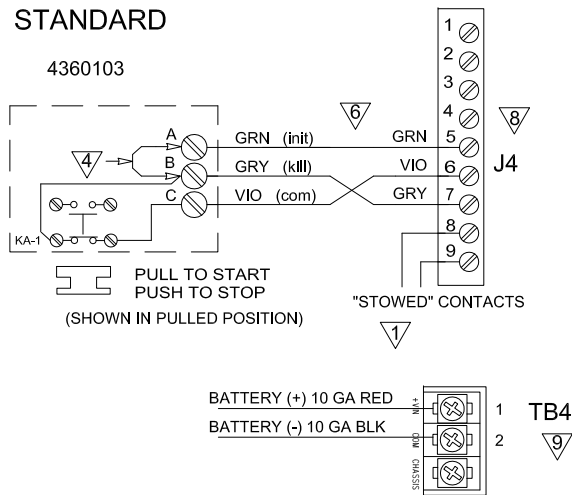

WIRELESS WITH NFPA E-STOP

KIT 4362101



NFPA

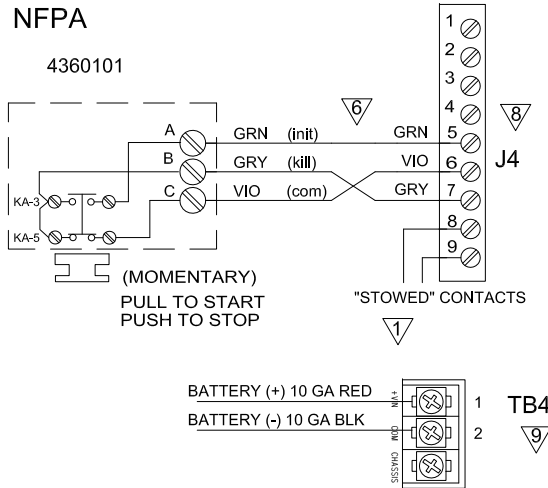

WIRELESS HHRC ONLY

KIT 4362109

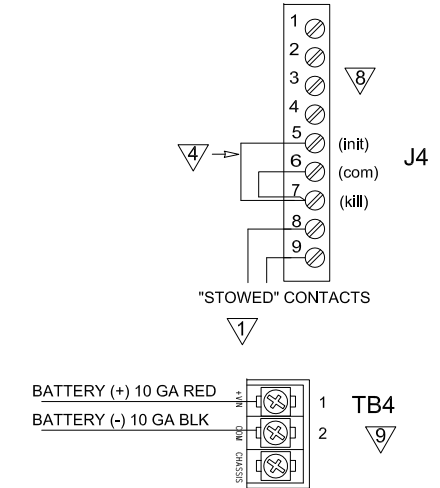

NOTES

- USE SW2 POSITION 1 ON BASE BOARD TO SELECT OPEN OR CLOSED WHEN NESTED. (SOFTWARE 6.3 AND HIGHER)
SW2-1 OPEN = CONTACTS CLOSED WHEN NESTED
SW2-1 CLOSED = CONTACTS OPEN WHEN NESTED.
2 AMPS MAX CURRENT, 20 GA. MINIMUM CONDUCTOR.
- SW2 POSITION 2 ON BASE BOARD MUST BE OPEN (NFPA MODE)
- SW2 POSITION 2 ON BASE BOARD MUST BE CLOSED (STANDARD MODE)
- REMOVE JUMPER(S) IF REPLACED BY PARKING BRAKE INTERLOCK. G-H CLOSED WHEN BRAKE "ON".
AVAILABLE IN STANDARD MODE ONLY.
- CABLE PART NUMBER 403250x
- CABLE PART NUMBER 452180x
- OPTIONAL DISABLE INPUT, CUSTOMER SUPPLIED CONTACTS. MUST HAVE CONTINUITY TO FUNCTION. WILL NOT ALLOW OPERATION IF OPEN, ACTS AS EMERGENCY STOP.
- 4.4in-lbs, 0.5Nm
- 20 in-lbs, 2.3Nm

PROGRAMMING THE HHRC WIRELESS ADDRESS

- SET THE DESIRED HHRC ADDRESS USING DIPSWITCH S3 ON THE BASE BOARD.
- TURN BASE UNIT POWER ON.
- PRESS THE MAST UP AND MAST DOWN BUTTONS SIMULTANEOUSLY FOR ONE SECOND. THE LED ON THE HHRC WILL FLASH RED AND GREEN.

AutoCAD Drawing: NS J-Box Wiring.DWG	UNLESS OTHERWISE SPECIFIED DIMENSIONS ARE IN INCHES	THIS DOCUMENT CONTAINS PROPRIETARY INFORMATION AND SHALL NOT BE USED OR REPRODUCED OR ITS CONTENTS DISCLOSED IN WHOLE OR IN PART, WITHOUT THE PRIOR WRITTEN CONSENT OF THE WILL-BURT COMPANY. FOR LOGISTICAL SUPPORT ONLY	AN EMPLOYEE OWNED COMPANY ORRVILLE, OHIO
FINISH	TOLERANCES ON: DECIMALS ANGLES 0 ± ± 1/2" 00 ± ± 000 ± ±	SIGNATURE DR. BY DJB - CK. BY JDN - APP. BY	NEXT ASSY DESC. NIGHTSCAN CHIEF ROOF-MOUNT WIRELESS HHRC, NFPA OR STANDARD
	FRACTIONS ± BREAK ALL SHARP CORNERS 125/ ON ALL MACHINED SURFACES	DATE -	SCALE DWG. No. WD-72007
			SHEET 1 OF 1

PANEL MOUNT (NFPA) ONLY

KIT 4236713



REVISIONS				
ECN	REV	DESCRIPTION	DATE	BY/APPVL
10207	00	NEW	09-07-10	DJB/JDN

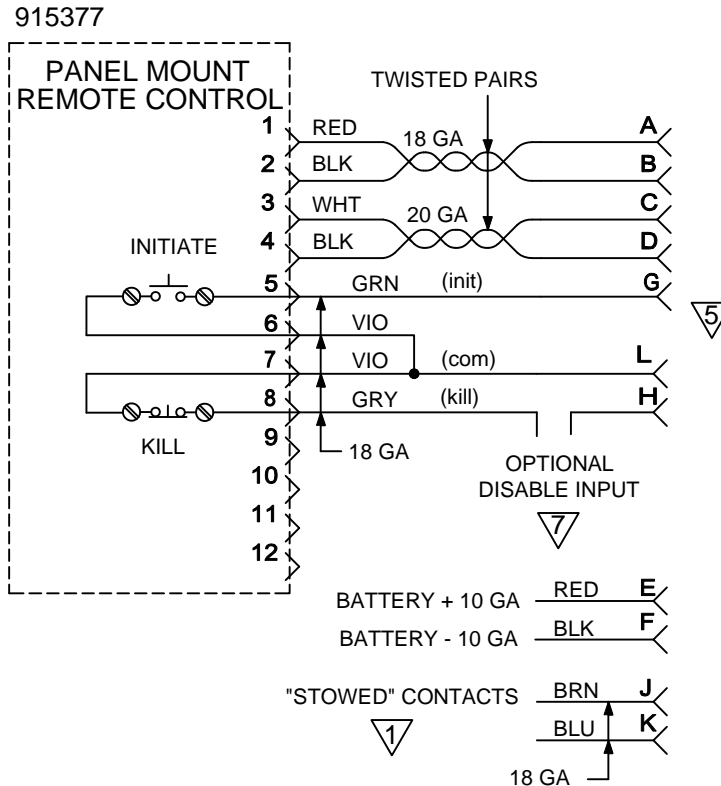

NOTES

- USE SW2 POSITION 1 ON BASE BOARD TO SELECT OPEN OR CLOSED WHEN NESTED.
(SOFTWARE 6.3 AND HIGHER)
SW2-1 OPEN = CONTACTS CLOSED WHEN NESTED
SW2-1 CLOSED = CONTACTS OPEN WHEN NESTED.
2 AMPS MAX CURRENT, 20 GA. MINIMUM CONDUCTOR.
- SW2 POSITION 2 ON BASE BOARD MUST BE OPEN (NFPA MODE)
- SW2 POSITION 2 ON BASE BOARD MUST BE CLOSED (STANDARD MODE)
- REMOVE JUMPER(S) IF REPLACED BY PARKING BRAKE INTERLOCK. G-H CLOSED WHEN BRAKE "ON".
AVAILABLE IN STANDARD MODE ONLY.
- VERTICAL: 4032502 (30 FT. CABLE), 4032503 (50 FT. CABLE)
ROOF-MOUNT: 4032505 (30 FT. CABLE), 4032506 (50 FT. CABLE)
- 4032101 (20 FT. CABLE), 4032102 (50 FT. CABLE)
- OPTIONAL DISABLE INPUT, CUSTOMER SUPPLIED CONTACTS. MUST HAVE CONTINUITY TO FUNCTION. WILL NOT ALLOW OPERATION IF OPEN, ACTS AS EMERGENCY STOP.
- 4.4in-lbs, 0.5Nm
- 20 in-lbs, 2.3Nm

AutoCAD Drawing: NS J-Box Wiring.DWG	UNLESS OTHERWISE SPECIFIED DIMENSIONS ARE IN INCHES	THIS DOCUMENT CONTAINS PROPRIETARY INFORMATION AND SHALL NOT BE USED OR REPRODUCED OR ITS CONTENTS DISCLOSED IN WHOLE OR IN PART, WITHOUT THE PRIOR WRITTEN CONSENT OF THE WILL-BURT COMPANY.	AN EMPLOYEE OWNED COMPANY ORRVILLE, OHIO
FINISH	TOLERANCES ON: DECIMALS ANGLES 0 = ± ± 1/2" 00 = ± ± 000 = ± ±	FOR LOGISTICAL SUPPORT ONLY	NEXT ASSY
	FRACTIONS ±	SIGNATURE DATE	DESC. NIGHTSCAN CHIEF VERTICAL NFPA SINGLE HARD-WIRED PANEL MOUNT
	BREAK ALL SHARP CORNERS 1/32" ON ALL MACHINED SURFACES	DR. BY DJB - CK. BY JDN -	SIZE DWG. No. B WD-72021
		APP. BY	SCALE NTS SHEET 1 OF 1

REVISIONS

ECN	REV	DESCRIPTION	DATE	BY/APPVL
10207	00	NEW	09-07-10	DJB/JDN

NFPA J-BOX

KIT 4236714

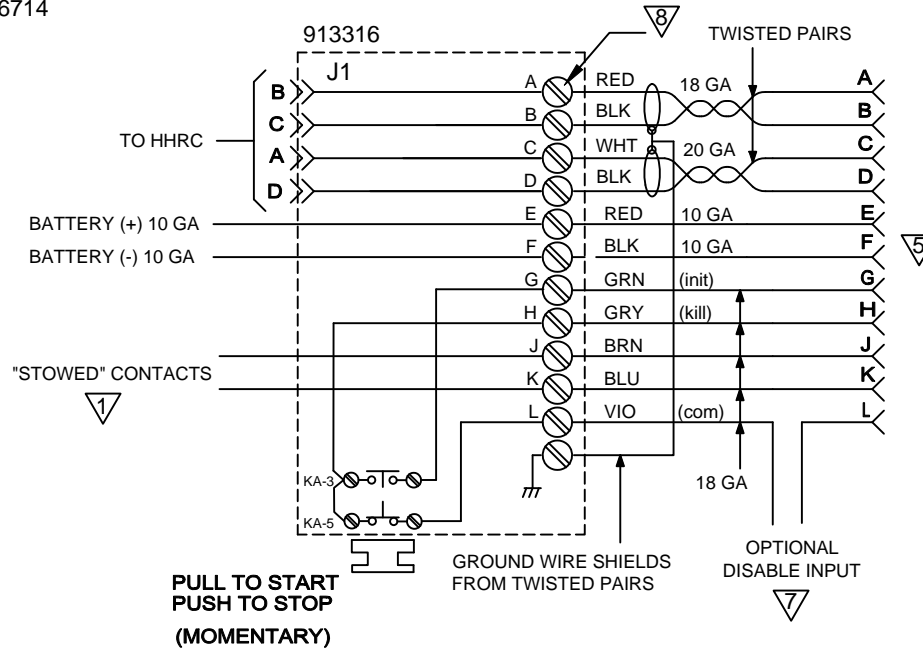

NOTES

- USE SW2 POSITION 1 ON BASE BOARD TO SELECT OPEN OR CLOSED WHEN NESTED.
(SOFTWARE 6.3 AND HIGHER)
SW2-1 OPEN = CONTACTS CLOSED WHEN NESTED
SW2-1 CLOSED = CONTACTS OPEN WHEN NESTED.
2 AMPS MAX CURRENT, 20 GA. MINIMUM CONDUCTOR.
- SW2 POSITION 2 ON BASE BOARD MUST BE OPEN (NFPA MODE)
- SW2 POSITION 2 ON BASE BOARD MUST BE CLOSED (STANDARD MODE)
- REMOVE JUMPER(S) IF REPLACED BY PARKING BRAKE INTERLOCK. G-H CLOSED WHEN BRAKE "ON".
AVAILABLE IN STANDARD MODE ONLY.
- VERTICAL: 4032502 (30 FT. CABLE), 4032503 (50 FT. CABLE)
ROOF-MOUNT: 4032505 (30 FT. CABLE), 4032506 (50 FT. CABLE)
- 4032101 (20 FT. CABLE), 4032102 (50 FT. CABLE)
- OPTIONAL DISABLE INPUT, CUSTOMER SUPPLIED CONTACTS. MUST HAVE CONTINUITY TO FUNCTION. WILL NOT ALLOW OPERATION IF OPEN, ACTS AS EMERGENCY STOP.
- 4.4in-lbs, 0.5Nm
- 20 in-lbs, 2.3Nm

AutoCAD Drawing: NS J-Box Wiring.DWG	UNLESS OTHERWISE SPECIFIED DIMENSIONS ARE IN INCHES TOLERANCES ON: DECIMALS ANGLES 0 = ± ± 1/2" 00 = ± ± 000 = ± ± FRACTIONS ± BREAK ALL SHARP CORNERS 1/32" ON ALL MACHINED SURFACES	THIS DOCUMENT CONTAINS PROPRIETARY INFORMATION AND SHALL NOT BE USED OR REPRODUCED OR ITS CONTENTS DISCLOSED IN WHOLE OR IN PART, WITHOUT THE PRIOR WRITTEN CONSENT OF THE WILL-BURT COMPANY. FOR LOGISTICAL SUPPORT ONLY SIGNATURE DATE DR. BY DJB - CK. BY JDN - APP. BY	 AN EMPLOYEE OWNED COMPANY ORRVILLE, OHIO NEXT ASSY DESC. NIGHTSCAN CHIEF VERTICAL NFPA SINGLE HARD-WIRED J-BOX SIZE DWG. No. WD-72022 SCALE NTS SHEET 1 OF 1
--	--	--	--

REVISIONS				
ECN	REV	DESCRIPTION	DATE	BY/APPVL
10207	00	NEW	09-07-10	DJB/JDN

STANDARD J-BOX 3

KIT 4236715

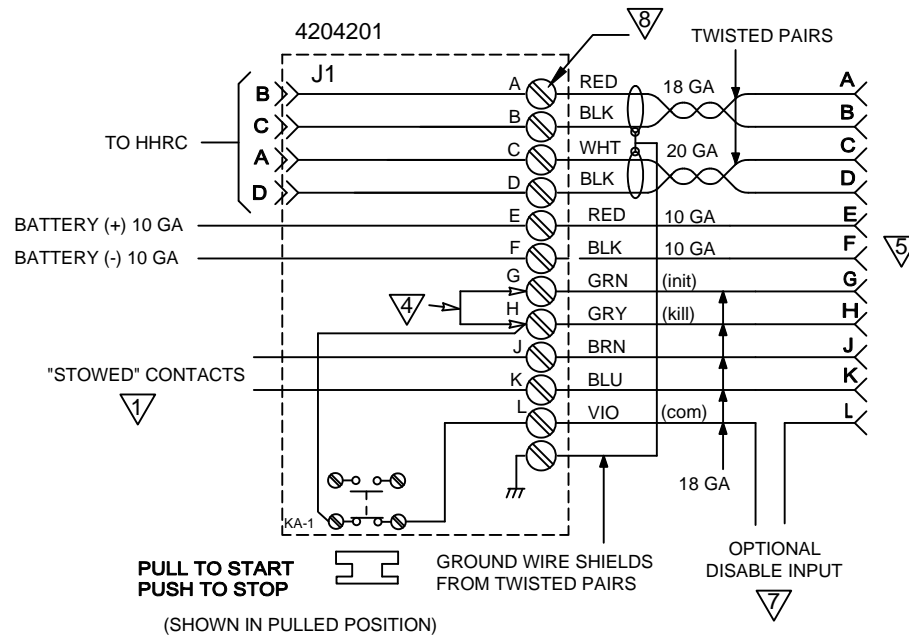

NOTES

- USE SW2 POSITION 1 ON BASE BOARD TO SELECT OPEN OR CLOSED WHEN NESTED.
(SOFTWARE 6.3 AND HIGHER)
SW2-1 OPEN = CONTACTS CLOSED WHEN NESTED
SW2-1 CLOSED = CONTACTS OPEN WHEN NESTED.
2 AMPS MAX CURRENT, 20 GA. MINIMUM CONDUCTOR.
- SW2 POSITION 2 ON BASE BOARD MUST BE OPEN (NFPA MODE)
- SW2 POSITION 2 ON BASE BOARD MUST BE CLOSED (STANDARD MODE)
- REMOVE JUMPER(S) IF REPLACED BY PARKING BRAKE INTERLOCK. G-H CLOSED WHEN BRAKE "ON".
AVAILABLE IN STANDARD MODE ONLY.
- VERTICAL: 4032502 (30 FT. CABLE), 4032503 (50 FT. CABLE)
ROOF-MOUNT: 4032505 (30 FT. CABLE), 4032506 (50 FT. CABLE)
- 4032101 (20 FT. CABLE), 4032102 (50 FT. CABLE)
- OPTIONAL DISABLE INPUT, CUSTOMER SUPPLIED CONTACTS. MUST HAVE CONTINUITY TO FUNCTION. WILL NOT ALLOW OPERATION IF OPEN, ACTS AS EMERGENCY STOP.
- 4.4in-lbs, 0.5Nm
- 20 in-lbs, 2.3Nm

AutoCAD Drawing: NS J-Box Wiring.DWG	UNLESS OTHERWISE SPECIFIED DIMENSIONS ARE IN INCHES TOLERANCES ON: DECIMALS ANGLES 0 = ± ± 1/2" 00 = ± ± 000 = ± ± FRACTIONS ± BREAK ALL SHARP CORNERS 1/32" ON ALL MACHINED SURFACES	THIS DOCUMENT CONTAINS PROPRIETARY INFORMATION AND SHALL NOT BE USED OR REPRODUCED OR ITS CONTENTS DISCLOSED IN WHOLE OR IN PART, WITHOUT THE PRIOR WRITTEN CONSENT OF THE WILL-BURT COMPANY. FOR LOGISTICAL SUPPORT ONLY SIGNATURE DATE DR.BY DJB - CK.BY JDN - APP.BY	 WILL BURT AN EMPLOYEE OWNED COMPANY ORRVILLE, OHIO NEXT ASSY DESC. NIGHTSCAN CHIEF VERTICAL STANDARD SINGLE HARD-WIRED J-BOX SIZE DWG. No. B WD-72023 SCALE NTS SHEET 1 OF 1
--	--	---	--

REVISIONS				
ECN	REV	DESCRIPTION	DATE	BY/APPVL
10207	00	NEW	09-07-10	DJB/JDN

(2) NFPA J-BOXES

KIT 4236716

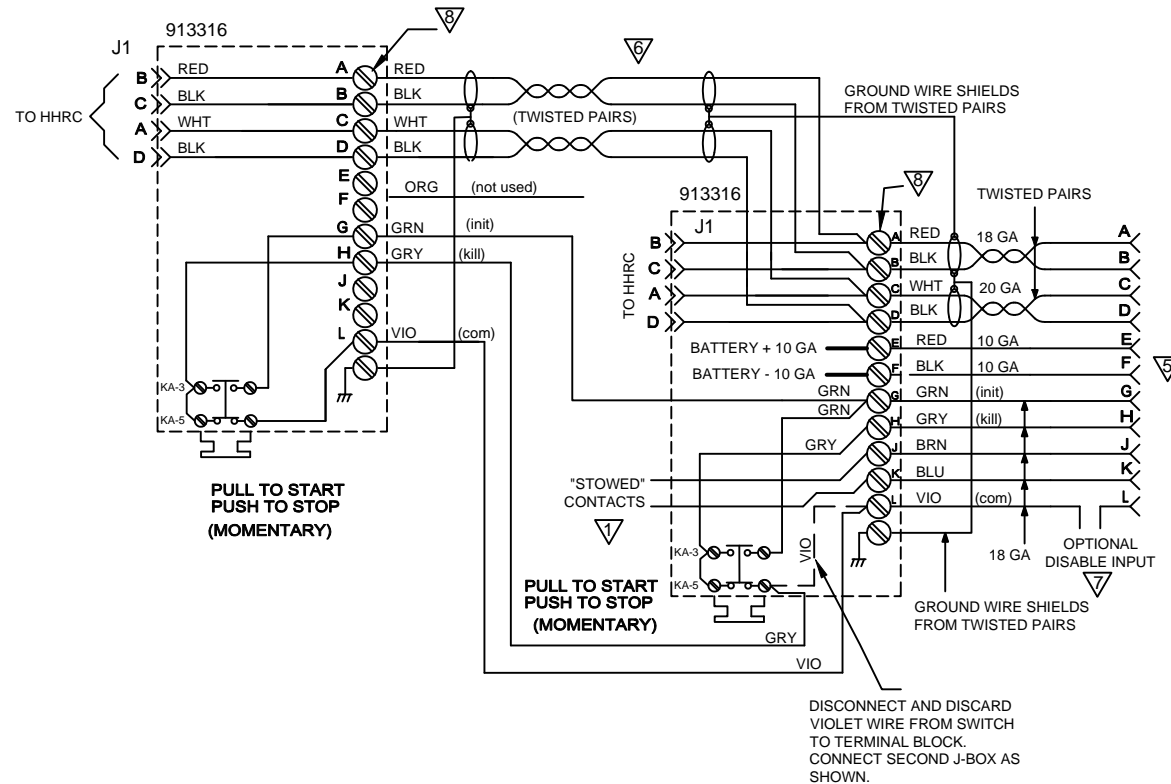

NOTES

- USE SW2 POSITION 1 ON BASE BOARD TO SELECT OPEN OR CLOSED WHEN NESTED.
(SOFTWARE 6.3 AND HIGHER)
SW2-1 OPEN = CONTACTS CLOSED WHEN NESTED
SW2-1 CLOSED = CONTACTS OPEN WHEN NESTED.
2 AMPS MAX CURRENT, 20 GA. MINIMUM CONDUCTOR.
- SW2 POSITION 2 ON BASE BOARD MUST BE OPEN (NFPA MODE)
- SW2 POSITION 2 ON BASE BOARD MUST BE CLOSED (STANDARD MODE)
- REMOVE JUMPER(S) IF REPLACED BY PARKING BRAKE INTERLOCK. G-H CLOSED WHEN BRAKE "ON".
AVAILABLE IN STANDARD MODE ONLY.
- VERTICAL: 4032502 (30 FT. CABLE), 4032503 (50 FT. CABLE)
ROOF-MOUNT: 4032505 (30 FT. CABLE), 4032506 (50 FT. CABLE)
- 4032101 (20 FT. CABLE), 4032102 (50 FT. CABLE)
- OPTIONAL DISABLE INPUT, CUSTOMER SUPPLIED CONTACTS. MUST HAVE CONTINUITY TO FUNCTION. WILL NOT ALLOW OPERATION IF OPEN, ACTS AS EMERGENCY STOP.
- 4.4in-lbs, 0.5Nm
- 20 in-lbs, 2.3Nm

AutoCAD Drawing: NS J-Box Wiring.DWG	UNLESS OTHERWISE SPECIFIED DIMENSIONS ARE IN INCHES	THIS DOCUMENT CONTAINS PROPRIETARY INFORMATION AND SHALL NOT BE USED OR REPRODUCED OR ITS CONTENTS DISCLOSED IN WHOLE OR IN PART, WITHOUT THE PRIOR WRITTEN CONSENT OF THE WILL-BURT COMPANY. FOR LOGISTICAL SUPPORT ONLY	AN EMPLOYEE OWNED COMPANY ORRVILLE, OHIO
	TOLERANCES ON: DECIMALS ANGLES $0 = \pm$ $\pm 1/2^\circ$ $00 = \pm$ $000 = \pm$		
FINISH	FRACTIONS \pm	SIGNATURE	DATE
	BREAK ALL SHARP CORNERS $1/32"$ ON ALL MACHINED SURFACES	DR. BY DJB	-
		CK. BY JDN	-
		APP. BY	
		SIZE	DWG. No. WD-72025
		SCALE	NTS
			SHEET 1 OF 1

REVISIONS				
ECN	REV	DESCRIPTION	DATE	BY/APPVL
10207	00	NEW	09-07-10	DJB/JDN

(2) STANDARD J-BOXES 3

KIT 4236717

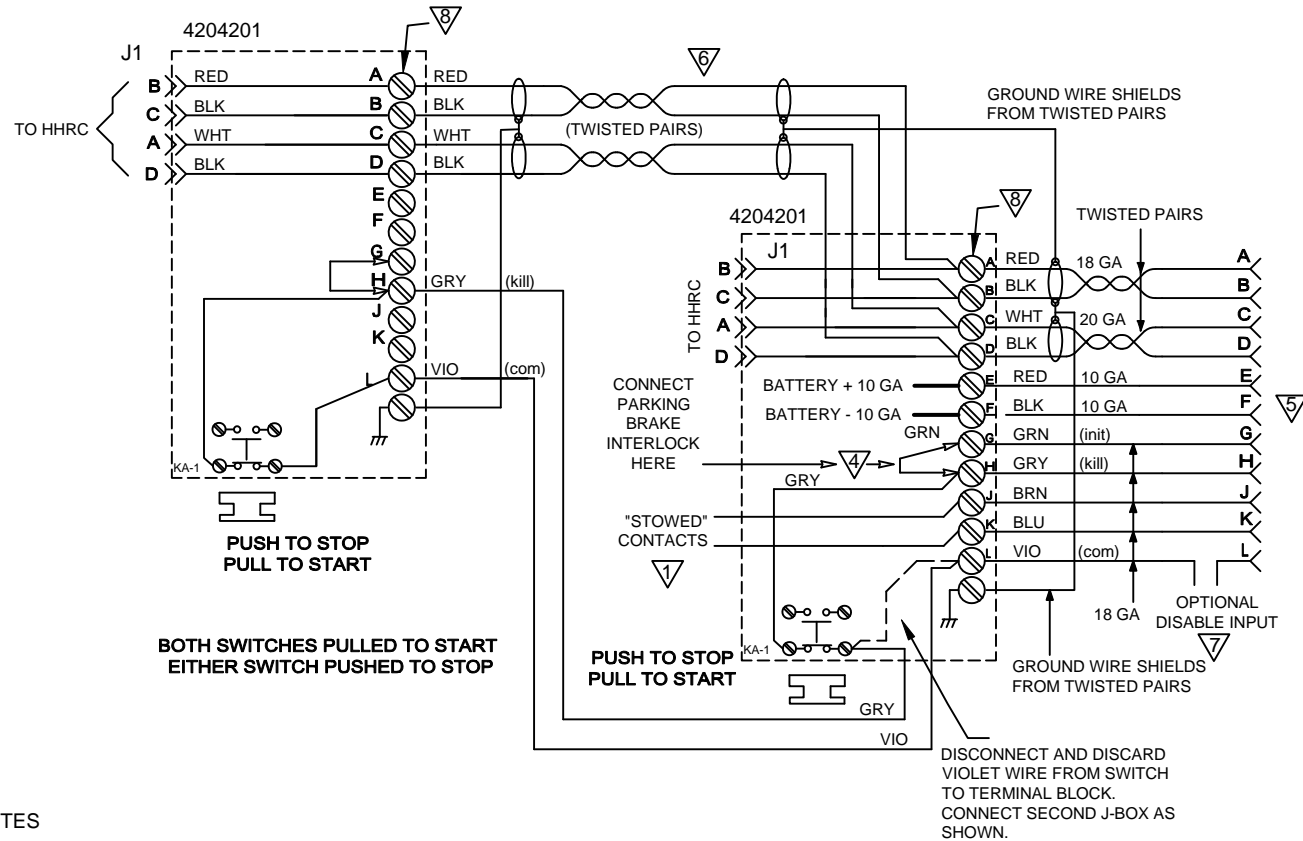

NOTES

- USE SW2 POSITION 1 ON BASE BOARD TO SELECT OPEN OR CLOSED WHEN NESTED.
(SOFTWARE 6.3 AND HIGHER)
SW2-1 OPEN = CONTACTS CLOSED WHEN NESTED
SW2-1 CLOSED = CONTACTS OPEN WHEN NESTED.
2 AMPS MAX CURRENT, 20 GA. MINIMUM CONDUCTOR.
- SW2 POSITION 2 ON BASE BOARD MUST BE OPEN (NFPA MODE)
- SW2 POSITION 2 ON BASE BOARD MUST BE CLOSED (STANDARD MODE)
- REMOVE JUMPER(S) IF REPLACED BY PARKING BRAKE INTERLOCK. G-H CLOSED WHEN BRAKE "ON".
AVAILABLE IN STANDARD MODE ONLY.
- VERTICAL: 4032502 (30 FT. CABLE), 4032503 (50 FT. CABLE)
ROOF-MOUNT: 4032505 (30 FT. CABLE), 4032506 (50 FT. CABLE)
- 4032101 (20 FT. CABLE), 4032102 (50 FT. CABLE)
- OPTIONAL DISABLE INPUT, CUSTOMER SUPPLIED CONTACTS. MUST HAVE CONTINUITY TO FUNCTION. WILL NOT ALLOW OPERATION IF OPEN, ACTS AS EMERGENCY STOP.
- 4.4in-lbs, 0.5Nm
- 20 in-lbs, 2.3Nm

AutoCAD Drawing: NS J-Box Wiring.DWG	UNLESS OTHERWISE SPECIFIED DIMENSIONS ARE IN INCHES	THIS DOCUMENT CONTAINS PROPRIETARY INFORMATION AND SHALL NOT BE USED OR REPRODUCED OR ITS CONTENTS DISCLOSED IN WHOLE OR IN PART, WITHOUT THE PRIOR WRITTEN CONSENT OF THE WILL-BURT COMPANY. FOR LOGISTICAL SUPPORT ONLY	AN EMPLOYEE OWNED COMPANY ORRVILLE, OHIO
	TOLERANCES ON: DECIMALS ANGLES 0 = ± ± 1/2° 00 = ± ° 000 = ± °		
FINISH	BREAK ALL SHARP CORNERS 1/32" ON ALL MACHINED SURFACES	SIGNATURE DR. BY DJB CK. BY JDN APP. BY	DATE - -
NEXT ASSY DESC. NIGHTSCAN CHIEF VERTICAL STANDARD TWO HARD-WIRED J-BOXES			SIZE B
DWG. No. WD-72026			SCALE NTS
SHEET 1 OF 1			