



RECOVERY AND WORK TRUCK LIGHTING SOLUTIONS



Will-Burt is the world's leading manufacturer of light towers. A line of fully integrated mobile lighting towers, the Night Scan® HDT Series, has been designed specifically for the towing, recovery and service truck industry.

The Night Scan® HDT Series has been engineered and manufactured in the USA for the harsh environments and extreme conditions you experience. Field proven across the country and around the world, the Night Scan® HDT is ready to become an important tool in your arsenal of equipment, improving the safety and efficiency of operations by turning night into day.

HDT
nightscan®

THE ADVANTAGES OF THE NIGHT SCAN® HDT SERIES

- Safety of nighttime recovery operations is enhanced with 360° of overhead light...turning night into day!
- Speed of safe recovery operations is increased with lighting that is in place and on in 15 seconds
- Years of service with maintenance-free design
- Fast Return on Investment
 - Increase your Revenue
 - Average charge per hour = \$250
- Record recovery scene events
 - Proof for insurance
 - Accurate billing
- Eliminates the need for a lighting trailer - light is always with the wrecker
- No generator required and self-contained system
- Retrofit to existing vehicle or install on a new build with small footprint
- Easy and fast operation with automatic deployment and stowing
- LED lights with a limited lifetime warranty Night Scan X200 and Sirion



TABLE OF CONTENTS



**HEAVY WRECKERS |
LARGE TRUCKS**
Night Scan®
Powerlite HDT 4-5



**ROLLBACKS | TOW
& UTILITY TRUCKS**
Night Scan® Fit
Night Scan® Chief 10-11



**HEAVY WRECKERS |
LARGE TRUCKS**
Night Scan® Powerlite
Vertical HDT 6-7



**ROLLBACKS | TOW
& UTILITY TRUCKS**
Night Scan® Chief Vertical
Night Scan® Chief Profiler
..... 12-13



**HEAVY WRECKERS |
LARGE TRUCKS**
Night Scan® Powerlite
Profiler HDT 8-9



**LED SCENE LIGHTING &
MONITORING**
Lamps | Smart Flares | Portable
and Rechargeable Lighting
Video Solutions 14-17

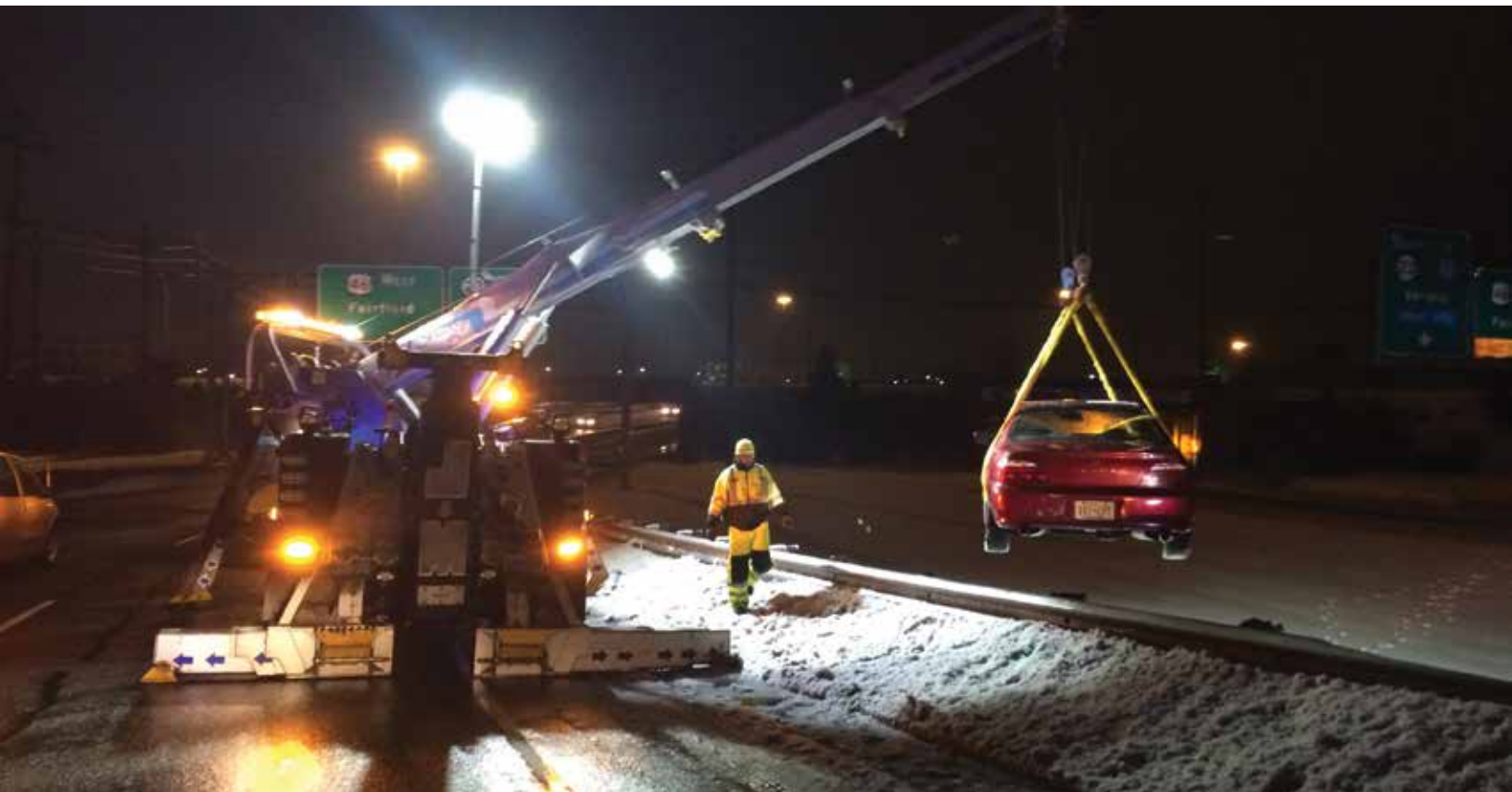



POWERLITE HDT

HEAVY WRECKERS & LARGE TRUCKS

- Improves nighttime safety and efficiency
- Increases Revenue
- No generator required, works from vehicle power
- Generates up to 220,000 lumens with optional Sirion LED light package featuring triple coverage optics
- Full independent rotation and tilt of both banks of lights – 360° of light
- Rapid recovery scene illumination in 15 seconds with the touch of one button
- Includes everything needed for installation
- For new installs or retrofit
- Optional wireless remote
- Optional video and recording

Powerlite HDT	WB 300	X200	Sirion
Height Extended (ft.)	15	15	15
Total Lumens	90,000	120,000	220,000
Weight with Lights (lbs.)	175	185	175
Tower Warranty	2 Years	2 Years	2 Years
Light Warranty	2 Years	Limited Lifetime	Limited Lifetime
Color Option	Standard color white. Black option for additional charge		



FOOTPRINT OF STOWED SYSTEM [L x W x H]

WB 300
75.19 x 41.56 x 10.69

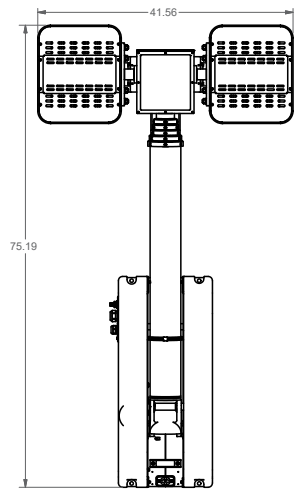

X200
76.06 x 33.56 x 11.58

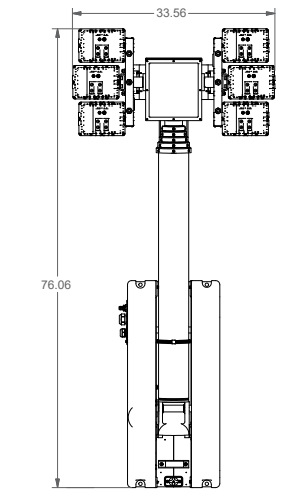

Sirion
77.87 x 42.05 x 11.40

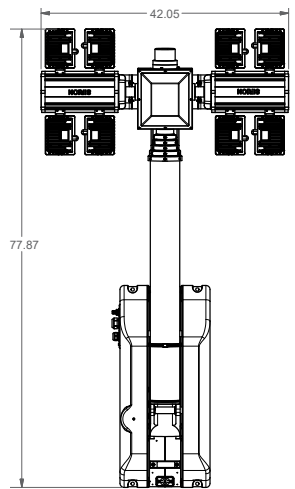

**Included Handheld
Wired Controller**



**Optional Universal
Wireless Controller**



**Optional LED Beacon Lights
[Amber, Blue, Clear, Red or Green]**





POWERLITE VERTICAL HDT

HEAVY WRECKERS & LARGE TRUCKS

- Improves nighttime safety and efficiency
- Increases Revenue
- No generator required, works from vehicle power
- Needs only 12” for installation
- Generates up to 220,000 lumens with optional Sirion LED light package featuring triple coverage optics
- Full independent rotation and tilt of both banks of lights – 360° of light
- Rapid recovery scene illumination in 15 seconds with the touch of one button
- Includes everything needed for installation
- For new installs or retrofit
- Optional wireless remote
- Optional video and recording

Powerlite Vertical HDT	WB 300	X200	Sirion
Height Extended (ft.)	15	15	15
Total Lumens	90,000	120,000	220,000
Weight with Lights (lbs.)	175	185	175
Tower Warranty	2 Years	2 Years	2 Years
Light Warranty	2 Years	Limited Lifetime	Limited Lifetime
Color Option	Standard color white. Black option for additional charge		



FOOTPRINT OF STOWED SYSTEM (L x W)

WB 300
70.38 x 41.56

X200
71.25 x 33.60

Sirion
73.06 x 40.56

**Included Handheld
Wired Controller**

**Optional Universal
Wireless Controller**

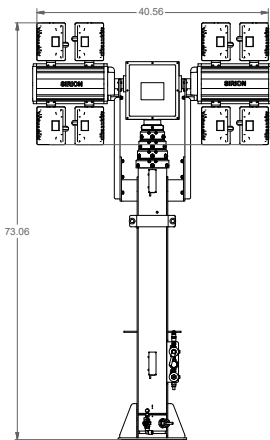
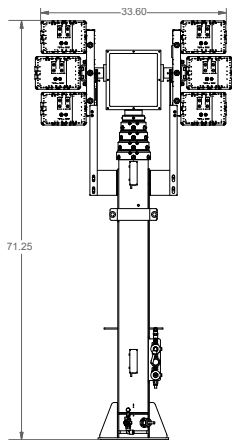
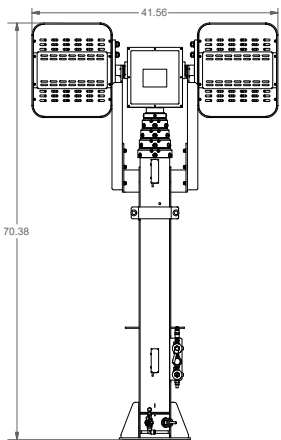

**Optional LED Beacon Lights
(Amber, Blue, Clear, Red or Green)**





POWERLITE PROFILER HDT

HEAVY WRECKERS & LARGE TRUCKS

- Improves nighttime safety and efficiency
- Increases Revenue
- No generator required, works from vehicle power
- Narrow profile saves space
- Generates up to 110,000 lumens with optional Sirion LED light package featuring triple coverage optics
- Full rotation and tilt control of lights
- Rapid recovery scene illumination in 15 seconds with the touch of one button
- Includes everything needed for installation
- For new installs or retrofit
- Optional wireless remote

Powerlite Profiler HDT	X200	Sirion
Height Extended (ft.)	12	12
Total Lumens	60,000	110,000
Weight with Lights (lbs.)	156	165
Tower Warranty	2 Years	2 Years
Light Warranty	Limited Lifetime	Limited Lifetime
Color Option	Standard color white. Black option for additional charge	



FOOTPRINT OF STOWED SYSTEM [L x W x H]

X200
77.38 x 14.88 x 12.50

Sirion
81.75 x 20.5 x 12.56

**Included Handheld
Wired Controller**

**Optional Universal
Wireless Controller**

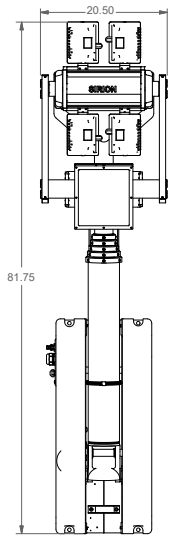
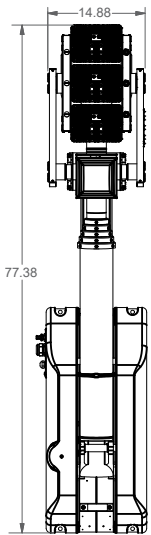

RECOVERY AND WORK TRUCK LIGHTING SOLUTIONS

The Night Scan Fit is a fully capable light tower with powerful LEDs to illuminate your work without blinding your crew. The lightweight design and narrow footprint allows the tower to be installed on your towing, recovery, or service truck. A remote-controlled positioner puts the light where you need it regardless of your apparatus' position and most importantly, it turns night into day, helping to keep your crew safe.

- Narrow - less than 16" with WB 140 lights
- Lightweight - less than 100 pounds with WB 140 lights
- Directs powerful LED light where you need it, regardless of the apparatus' position
- Easy to install, Self-contained system only requires 12V power

Night Scan Fit	WB 140	X200
Height Extended (ft.)	3.25	7.5
Total Lumens	56,000	80,000
Weight with Lights (lbs.)	94	110
Tower Warranty	2 Years	2 Years
Light Warranty	5 Years	Limited Lifetime
Color Option	Standard color white. Black option for additional charge	



NIGHT SCAN FIT

ROLLBACKS, TOW & UTILITY TRUCKS

FOOTPRINT OF STOWED SYSTEM [L x W x H]

WB 140

58.30 x 15.30 x 10.50

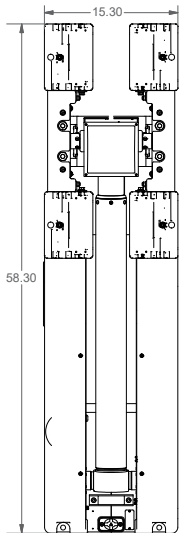

X200

60.30 x 16.40 x 10.50

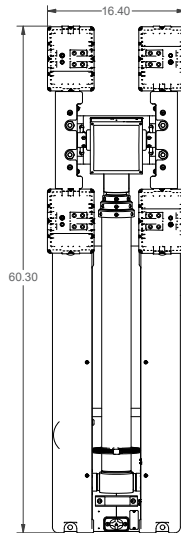

Included Handheld Wired Controller



Optional Universal Wireless Controller



Optional LED Beacon Lights (Amber, Blue, Clear, Red or Green)



- Improves nighttime safety and efficiency
- Increases Revenue
- No generator required, works from vehicle power
- Narrow profile saves space
- Generates up to 80,000 lumens with Night Scan X200 Spot and Flood LED lights
- Full rotation and tilt control of lights
- Rapid recovery scene illumination in 15 seconds with the touch of one button
- Includes everything needed for installation
- For new installs or retrofit
- Optional wireless remote



Chief HDT	WB 140	X200
Height Extended (ft.)	7.5	7.5
Total Lumens	56,000	80,000
Weight with Lights (lbs.)	94	110
Tower Warranty	2 Years	2 Years
Light Warranty	5 Years	Limited Lifetime
Color Option	Standard color white. Black option for additional charge	

CHIEF HDT

ROLLBACKS, TOW & UTILITY TRUCKS

FOOTPRINT OF STOWED SYSTEM (L x W x H)

WB 140
50.00 x 27.38 x 9.38

X200
53.25 x 27.50 x 9.38

Included Handheld Wired Controller

Optional Universal Wireless Controller

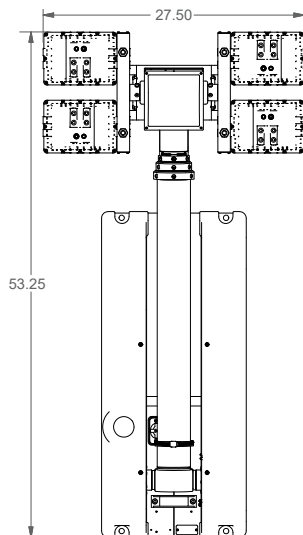
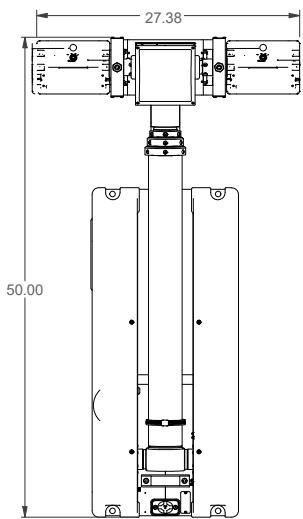

Optional LED Beacon Lights (Amber, Blue, Clear, Red or Green)



RECOVERY AND WORK TRUCK LIGHTING SOLUTIONS

- Improves nighttime safety and efficiency
- Increases Revenue
- No generator required, works from vehicle power
- Narrow profile saves space
- Generates up to 80,000 lumens with Night Scan X200 Spot and Flood LED lights
- Full rotation and tilt control of lights
- Rapid recovery scene illumination in 15 seconds with the touch of one button
- Includes everything needed for installation
- For new installs or retrofit
- Optional wireless remote

Chief Vertical HDT	WB 140	X200
Height Extended (ft.)	7.5	7.5
Total Lumens	28,000	80,000
Weight with Lights (lbs.)	95	122
Tower Warranty	2 Years	2 Years
Light Warranty	5 Years	Limited Lifetime
Color Option	Standard color white. Black option for additional charge	



CHIEF VERTICAL HDT

ROLLBACKS, TOW & UTILITY TRUCKS

FOOTPRINT OF STOWED SYSTEM (L x W)

WB 140
60.06 x 27.69

X200
65.00 x 27.38

**Included Handheld
Wired Controller**

**Optional Universal
Wireless Controller**

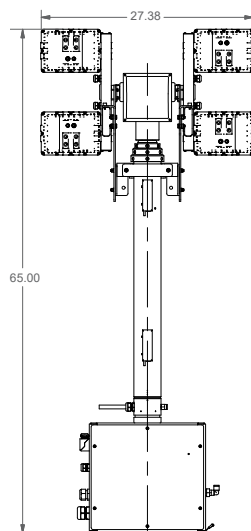
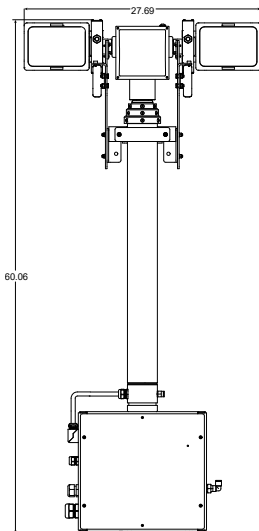

**Optional LED Beacon Lights
(Amber, Blue, Clear, Red or Green)**



- Improves nighttime safety and efficiency
- Increases Revenue
- No generator required, works from vehicle power
- Narrow profile saves space
- Built-in compressor - no truck air needed
- Generates up to 60,000 lumens with Night Scan X200 Spot and Flood LED lights
- Full rotation and tilt control of lights
- Rapid recovery scene illumination
- Includes everything needed for installation
- For new installs or retrofit
- Optional wireless remote

Chief Profiler HDT	X200
Height Extended (ft.)	7.5
Total Lumens	80,000
Weight with Lights (lbs.)	110
Tower Warranty	2 Years
Light Warranty	Limited Lifetime
Color Option	Standard color white. Black option for additional charge



CHIEF PROFILER HDT

ROLLBACKS, TOW & UTILITY TRUCKS

FOOTPRINT OF STOWED SYSTEM [L x W x H]

X200
69.13 x 14.81 x 10.50

**Included Handheld
Wired Controller**

**Optional Universal
Wireless Controller**

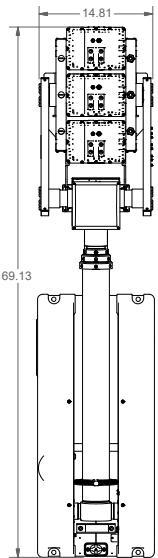



The Will-Burt and Night Scan family of LED lamps are the only LED scene lights designed specifically for Night Scan light towers. These lamps are engineered to optimize the inherent benefits of Night Scan towers, producing more light, using less power, and covering larger areas. Reliable in extreme environments, the Will-Burt and Night Scan family of LED lamps deliver maximum lighting performance and will always create light throughout the mission.

LED LAMPS

Will-Burt 140 | Night Scan X200
Will-Burt 300 | Night Scan Sirion

WILL-BURT 140



WILL-BURT 300



Night Scan X200



Night Scan Sirion®

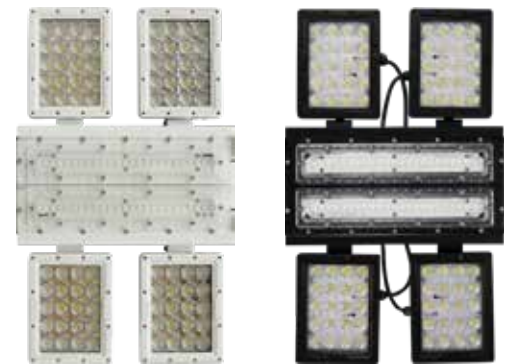

All models available in standard color white.
Black option for additional charge

Night Scan Sirion Profiler | 6 Lights



Model	Will-Burt 140	Will-Burt 300	Night Scan X200	Night Scan Sirion
Raw Lumens Per Fixture	14,000	45,000	20,000	110,000
Maximum Tower Lumens	84,000	90,000	120,000	220,000
Optics	Dual – Spot Flood	Dual – Spot Flood	Dual – Spot Flood	Triple – Spot Short Flood Long Flood
VDC / Watts Per Fixture	12 or 24 / 50	48 / 75	12 or 24 / 125	12 or 24 / 600
VAC / Watts Per Fixture	12 or 24 / 50	120 or 240 / 300	120 or 240 / 125	120 or 240 / 600
Waterproof Rating	IP68 – Dust tight, waterproof		IP69K – High pressure spray, waterproof	
Active Thermal Management	Yes	Yes	Yes	Yes
Color Option	Standard color white. Black option for additional charge			
Warranty	5 Years	2 Years	Limited Lifetime	Limited Lifetime

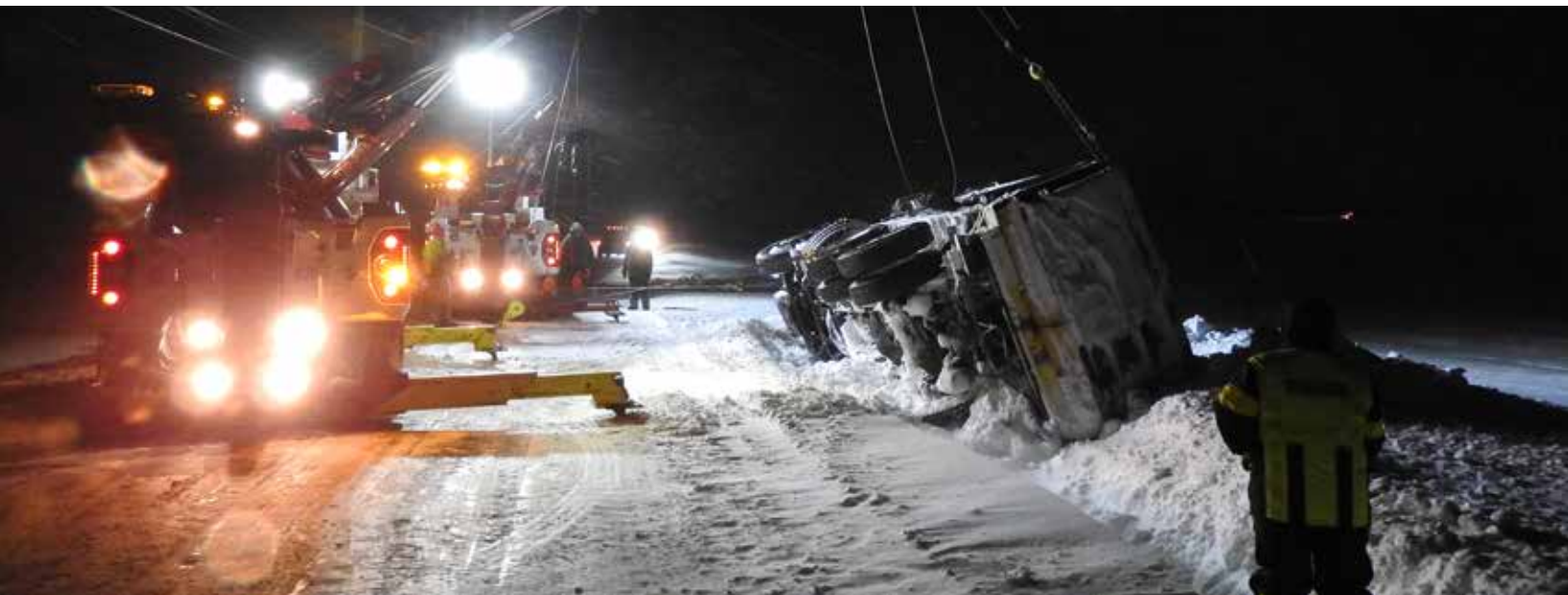



PI-LIT SMART FLARES

Sequential LED Hazard Warning Lights [6 and 10 Pack]



- Automatic synchronization of lights with no programming
- Rapid Deployment System automatically turns on lights when removed from carrying case
- Tilt sensor directs light output optimizing driver awareness
- Mode Memory saves light pattern, deployment order and activation settings for next use

- Pair Mode syncs single or multiple lights
- Battery status check with push of a button
- 20+ hour runtime and 6 hour charge time with Lithium-ion rechargeable battery
- IP66 water and dust rating
- Withstands weights up to 30,000 lbs.
- Available in 6 and 10 packs with orange, blue, or red flares
- 2-Year warranty

Run Time	20+ hour runtime (flash pattern dependent)	
Mode	4 flash patterns: 2 sequential 1 simultaneous 1 steady-burn	
Charging Time	6 hours from a completely depleted battery	
Ingress Protection	IP66	
Dimensions (in. / mm)	Flare: 4.25 x 3.5 x 1 / 108 x 89 x 25.4	
Weight (lb. / kg)	Flare: .5 / .02	
Code	Blue 6 Pack: 5873601	Blue 10 Pack: 5873501
	Orange 6 Pack: 5873401	Orange 10 Pack: 5873301
	Red 6 Pack: 5891001	Red 10 Pack: 5890901

Supplied with:
 Carrying Case
 DC 12/24V Vehicle Charger
 AC 110/240V Wall Charger

Optional Accessories:
 Cone mount [6 Pack]: 5873801
 AC USB Charging Adapter: 5872801



Red, Blue, and Orange Flares
6 and 10 packs available in each color



Magnetic Cone Adapter
Securely mounts single or multiple flares on top or both sides of the cone



RECHARGEABLE & PORTABLE LIGHTING SOLUTIONS



The Will-Burt Company is the proud, exclusive distributor of NightSearcher rechargeable lighting products. NightSearcher was established in 1989 and has provided the world with portable rechargeable lighting solutions that are dependable, durable, and easy to use. Applications of NightSearcher products range through multiple markets including towing, law enforcement, fire, security, construction, mining, and more. All products are powered by no maintenance lithium-ion or LFP batteries providing longevity and reliability in temperatures from -4° to 140° F, as well as containing a battery management system to protect against overcharging. While NightSearcher is located in the United Kingdom, Will-Burt holds stock of core products within the United States to ensure fast delivery.

NightSearcher professional products are carefully designed and manufactured to the highest standards to ensure the reliability and durability our customers need. This is why we offer a 3-year standard warranty on all manufacturing defects and 1-year warranty on all rechargeable batteries from the date of purchase.



VIDEO SOLUTIONS

Video Cameras, Controllers and Real-time Monitoring



Will-Burt's video packages have been designed for integration into a wide variety of elevation and light tower solutions. The Night Scan® Chief, Powerlite and Vertical Light Towers deliver the capability of camera mounting, along with telescopic masts. A camera, elevated to a height from 5 ft. to 50 ft. above the vehicle roof allows ground personnel to survey an emergency scene quickly and efficiently. In addition, the camera offers real-time monitoring and surveillance for accurate records and documentation.

Integrated Video solutions have been specifically designed for many industries such as Towing, First Responders, Fire, Broadcast, Security, Police, Oil and Gas, Mining and Construction. Will-Burt can also design custom packages to meet your unique requirements.

From basic fixed cameras to advanced high definition, IP enabled cameras with thermal imaging, Will-Burt offers a model that will fit your needs. All video options can be integrated with a Will-Burt telescopic mast or light tower providing the most advanced surveillance and recording possible.



Model	HD VIDEO CAMERA				THERMAL IMAGER		
	WONWOO	*Viper HD IP POE	Analog	Infiniti Triton	Infiniti Triton + Thermal Imager		
Camera Type	PTZ - SDI or IP with IR Illuminator	PTZ - H.265 HD	Analog	HD IP POE PTZ Camera Plus IR Illuminator	HD IP PTZ Camera Plus Thermal Imager	Image Sensor	Uncooled VOx Microbolometer
Lens	4.7mm - 94.0mm	4.3mm - 129mm	8mm / 2.8 mm	4.8mm to 144.0mm	4.8mm to 144.0mm	Lens	19mm f/1.0
Image Sensor	1/3" 2.2M Pixel CMOS Sensor	1/2.8" Exmor CMOS 2.14 Megapixel	Sharp CCD	2.4MP 1/2.8" CMOS	2.4MP 1/2.8" CMOS	Field of View	13.8° Horizontal FOV
Resolution	1920 x 1080 pixels - 1080p	1080p x 720p	510 x 492 / 420 TV lines	2MP/1080p @ 30fps [1920 x 1080]	2MP/1080p @ 30fps [1920 x 1080]	Resolution	384 x 288
Optical Zoom / Digital Zoom	20x / 12x	30x / 12x	Fixed	30x / 16x	30x / 16x	Pixel Pitch	12µm
Low Light [LUX]	0.0005 with 12 IR LED's / 120m	High On: 0.00013 Mode Off: 0.0008	0 with 10 IR LED's	Color: 0.005 @ f/1.5 B&W: 0.0005 @ f/1.5	Color: 0.005 @ f/1.5 B&W: 0.0005 @ f/1.5	Spectral Range	7,000-14,000nm [LWIR]
Pan & Tilt	360° endless pan / 15° - 270° tilt	360° continuous pan & tilt	No	360° continuous pan, -25° to +90° tilt	360° continuous pan, -25° to +90° tilt	Thermal Sensitivity	50mK
Ingress Protection	IP66 - Outdoors	IP68	IP67 - Waterproof	IP66	IP66	Frequency	30Hz
Warranty	1 year	2 years	1 year	1 year	1 year	Image Display	White Hot
						Focus	Athermalized

*The Viper HD IP Camera must be used in conjunction with a customer supplied AC or DC power injector.

CONTACT YOUR SALES REPRESENTATIVE TODAY



Contact Us
Complete a Contact Form

WILL-BURT NORTH AMERICA
WORLD HEADQUARTERS

401 Collins Boulevard, Orrville, OH 44667 USA
Telephone: +1 330 682 7015
Mast Customer Service: +1 330 684 4000
Fax: +1 330 684 1190
Email: info@willburt.com

WILL-BURT
UNITED KINGDOM

Unit 5b, Station Approach, Four Marks,
Alton Hampshire, GU34 5HN, United Kingdom
Telephone: +44 (0) 1403 265532
Fax: +44 (0) 1403 259072
Email: info@willburt.com

WILL-BURT INTEGRATION
ALUMA TOWER | ITS

7750 9th Street SW
Vero Beach, FL 32968 USA
Telephone: +1 772 567 3423 | +1 800 850 8535
Fax: +1 772 567 3432
Aluma Tower Email: info@alumatower.com
ITS Email: programs@itstowers.com

WILL-BURT ASIA
SINGAPORE SALES OFFICE

1 Fullerton Road, #02-01
One Fullerton, Singapore 049213
Telephone: +65 6832 5689
Fax: +65 6722 0664
Email: info@willburt.com

WILL-BURT
GERMANY

Fischerergasse 25
D-91344 Waischenfeld, Germany
Telephone: +49 9202 180
Fax: +49 9202 1811
Email: info@willburt.com

CLARK MASTS
A WILL-BURT COMPANY

18-20 Ringwood Road, Binstead,
Isle of Wight, PO33 3PA, England
Telephone: +44 (0) 1983 563691/567090
Fax: +44 (0) 1983 566643/811157
E-mail: sales@clarkmasts.com

The Will-Burt Company, headquartered in Orrville, Ohio, USA, is the world's premier manufacturer of mobile telescoping masts, towers and pan and tilt positioners. We offer virtually every mobile payload elevation and integration solution for defense, government, first responders, cellular and mobile, broadcast, energy production and other markets. Will-Burt also offers contract manufacturing, metal fabrication, powder-coating, and rapid prototyping services. Will-Burt is an international company with offices and manufacturing in the USA, England, and Germany along with offices in Singapore. All Will-Burt Company manufacturing locations are backed by a certified ISO 9001:2015 Quality Management System. Incorporated in 1918, Will-Burt is 100% employee-owned and is classified as a small business.

*Disclaimer: Dimensions and weights are for reference only and are subject to change.
Please contact Will-Burt for current engineering specifications.*



Will-Burt Terms and Conditions of Sale:
<https://www.willburt.com/support/service/will-burt-terms-conditions-of-sale/>

December, 2025
The Will-Burt Company
ISO 9001:2015
INNOVATION ELEVATED®