

ASSEMBLY NO	ITEM 3 PART NO	ITEM 3 DESCRIPTION
720611040	4596601	FRC LED 2 LT, 180W (2-90W 12/24VDC) WHT
720611240	4596602	FRC LED 2 LT, 300W (2-150W 12/24VDC) WHT

REVISION HISTORY				
ECN	REV	DESCRIPTION	DATE	BY/APPR
10452	A	INITIAL RELEASE	2/28/2011	SMB\

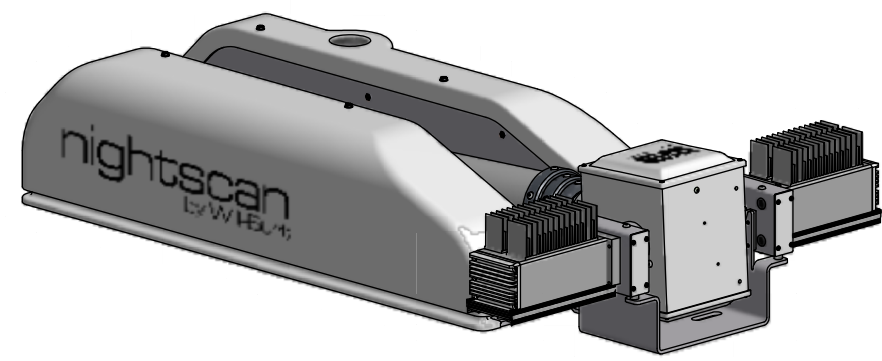

ISO VIEW

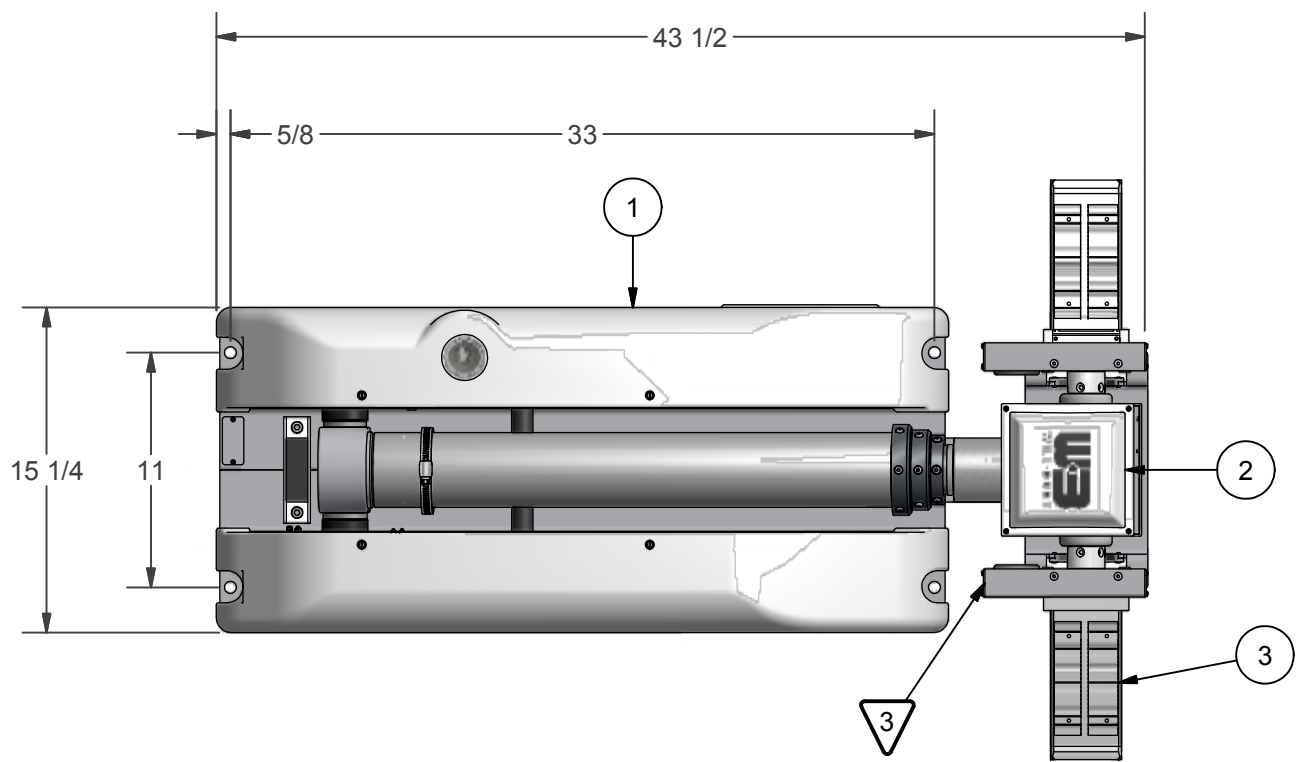

BOM			
ITEM	QTY	PART NUMBER	DESCRIPTION
1	1	4522003	NSC BASE ASSEMBLY 6.0 WHITE
2	1	4548301	NSC RCP, LIGHTS ONLY
3	1	SEE TABLE	LIGHT KIT
4	1	4558901	NSC LABEL KIT (NOT SHOWN)
5	1	900600	MAST OIL (SHIP LOOSE) (NOT SHOWN)
6	1	TP-4602001	MANUAL, NS 1.8/2.3, CE, CD VERSION (NOT SHOWN)
7	1	4584001	FILLER, CORRUGATED NSC (NOT SHOWN)

NOTES:

- 1 APPLY RTV #739 OR EQUAL TO ALL OPEN HOLES.
- 2 SEE WIRING DIAGRAM 46066 FOR ALL UNITS.
- 3 SET LIGHT BARS HOME POSITION PARALLEL TO BASE PLATE WHEN STOWED.

UNLESS OTHERWISE SPECIFIED DIMENSIONS ARE IN INCHES.
 TOLERANCES ON DECIMALS ANGLES
 0 = ± 0.030 ± 1/2°
 00 = ± 0.010
 000 = ± 0.005
 FRACTIONAL ± 1/64"
 1. ALL INSIDE EDGES TO HAVE .005" TO .035" FILLETS.
 2. ALL OUTSIDE EDGES TO HAVE .005" TO .015" CHAMFER OR RADIUS.
 125° ON ALL MACHINED SURFACES

PROPRIETARY AND CONFIDENTIAL
 THE INFORMATION CONTAINED IN THIS DRAWING IS THE SOLE PROPERTY OF THE WILL-BURT COMPANY ANY REPRODUCTION IN PART OR WHOLE WITHOUT THE WRITTEN PERMISSION OF THE WILL-BURT COMPANY IS PROHIBITED.



TITLE
**NS 1.8-180-2 LED
 12VDC-FRC**

APPROX. WT:84.1 lbmass

THIRD ANGLE PROJECTION



APPROVALS	DATE
DRAWN SMB	2/28/2011
CHECKED	

SIZE	DWG NO	REV
B	720611040	A

PN:	SHEET 1 OF 1
720611040	