

REVISION HISTORY				
ECN	REV	DESCRIPTION	DATE	APPROVED
11123	N	INITIAL DRAWING	7/19/2012	DAS

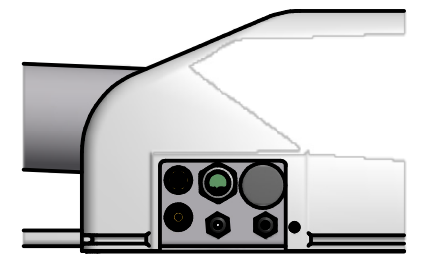

SECTION A-A

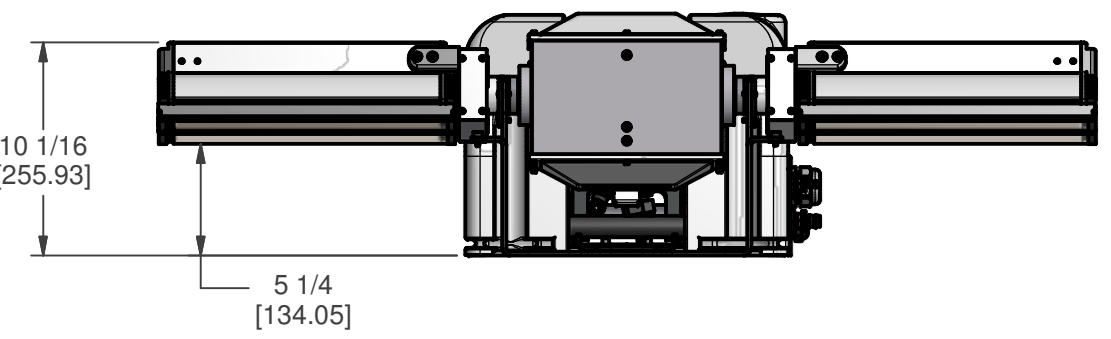
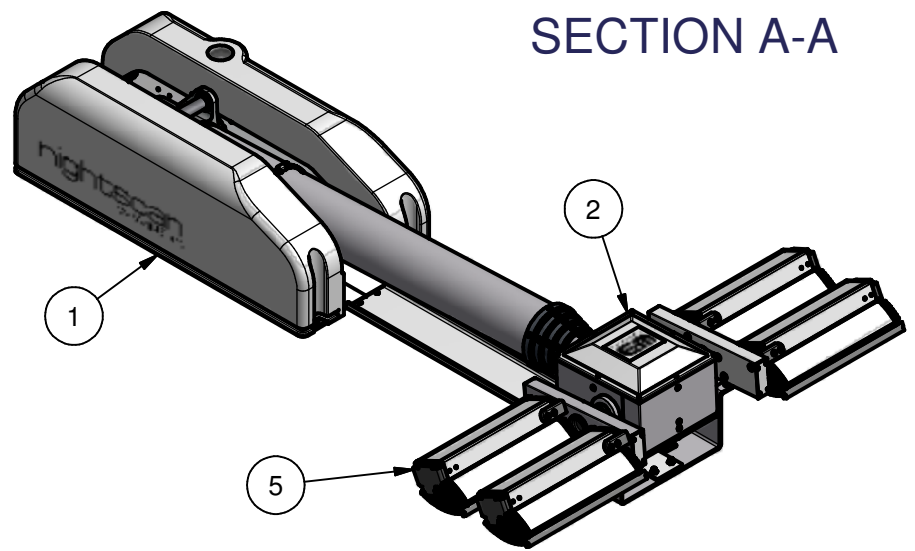

NOTE:
SECONDARY DIMENSIONS - MILLIMETERS NOTED IN BRACKETS

MATERIAL	UNLESS OTHERWISE SPECIFIED DIMENSIONS ARE IN INCHES. TOLERANCES ON: DIMENSIONS ±0.005 ANGLES ±1° 1. ALL ANGLES 90° 2. ALL INSIDE EDGES TO HAVE .005" TO .035" FILLETS. 3. ALL OUTSIDE EDGES TO HAVE .005" TO .015" CHAMFER OR RADIUS. 125 ON ALL MACHINED SURFACES	PROPRIETARY AND CONFIDENTIAL THE INFORMATION CONTAINED IN THIS DRAWING IS THE SOLE PROPERTY OF THE WILL-BURT COMPANY ANY REPRODUCTION IN PART OR WHOLE WITHOUT THE WRITTEN PERMISSION OF THE WILL-BURT COMPANY IS PROHIBITED.		WILL-BURT AN EMPLOYEE OWNED COMPANY ORRVILLE, OH	
FINISH				TITLE NS 4.5-6000 OPTIMUM 220 VAC WHITE	
APPROX. WT:N/A				APPROVALS DRAWN dasmith	DATE 7/19/2012
THIRD ANGLE PROJECTION			CHECKED	PN: 721549010	SHEET 1 OF 2

**BOTTOM VIEW
MOUNTING BOLT PATTERN**

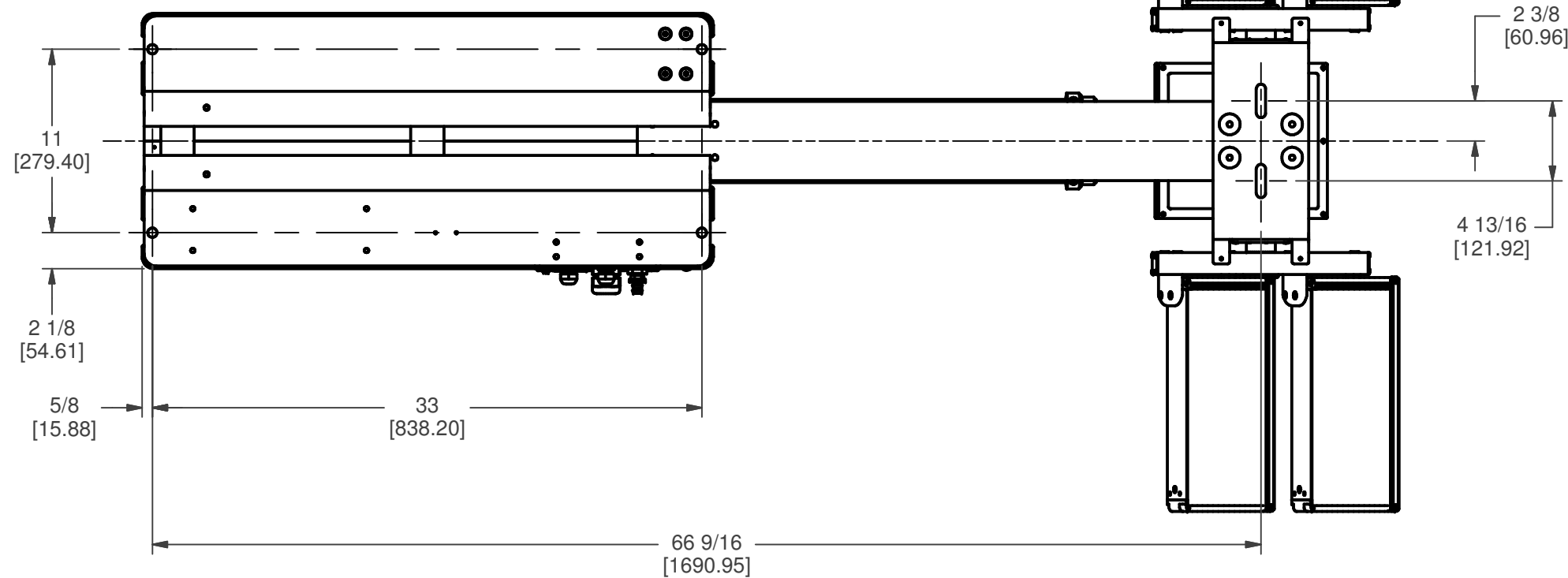

NOTE:

- 1 APPLY RTV #739 OR EQUAL TO ALL OPEN HOLES
- 2 SEE WIRING DIAGRAM WD-46276 FOR WIRING DETAILS
- 3 SET LIGHT BARS HOME POSITION PARALLEL TO BASE PLATE WHEN STOWED
- 4 APPLY LOCTITE #242 OR EQUAL TO ALL THREADS UNLESS OTHERWISE NOTED
- 5 APPLY A COAT OF SILICONE GREASE TO RCP MOTOR BORES PRIOR TO SHAFTS BEING INSTALLED

BOM			
ITEM	QTY	PART NUMBER	DESCRIPTION
1	1	4627601	BASE ASSEMBLY NSP
2	1	4742501	RCP ASSEMBLY NSP STD
3	1	4706701	NSP LABEL KIT (NOT SHOWN)
4	1	4807801	KIT, SHIPPING NSP (NOT SHOWN)
5	1	4574601	OPT. 6000W(4) X 1500) LIGHT KIT 220V WH

MATERIAL	UNLESS OTHERWISE SPECIFIED DIMENSIONS ARE IN INCHES. TOLERANCES ON: DIMENSIONS ±0.005 ANGLES ±1° 1. ALL ANGLES 90° 2. ALL INSIDE EDGES TO HAVE .005" TO .035" FILLETS. 3. ALL OUTSIDE EDGES TO HAVE .005" TO .015" CHAMFER OR RADIUS. 125 ON ALL MACHINED SURFACES	PROPRIETARY AND CONFIDENTIAL THE INFORMATION CONTAINED IN THIS DRAWING IS THE SOLE PROPERTY OF THE WILL-BURT COMPANY ANY REPRODUCTION IN PART OR WHOLE WITHOUT THE WRITTEN PERMISSION OF THE WILL-BURT COMPANY IS PROHIBITED.		 AN EMPLOYEE OWNED COMPANY ORRVILLE, OH TITLE NS 4.5-6000 OPTIMUM 220 VAC WHITE		
FINISH		APPROVALS	DATE	SIZE	DWG NO	REV
APPROX. WT:N/A	THIRD ANGLE PROJECTION	DRAWN dasmith CHECKED	7/19/2012	B	721549010	N
				PN:	721549010	SHEET 2 OF 2