

REVISION HISTORY				
ECN	REV	DESCRIPTION	DATE	BY/APPR
10599	00	INITIAL RELEASE	7/9/2007	AW

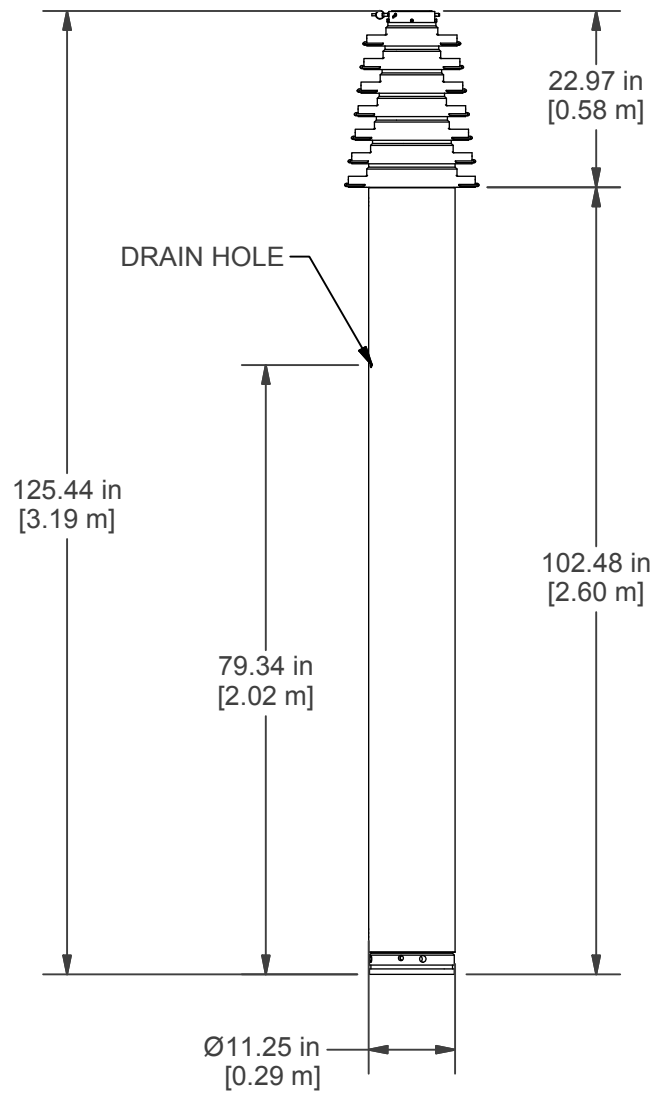
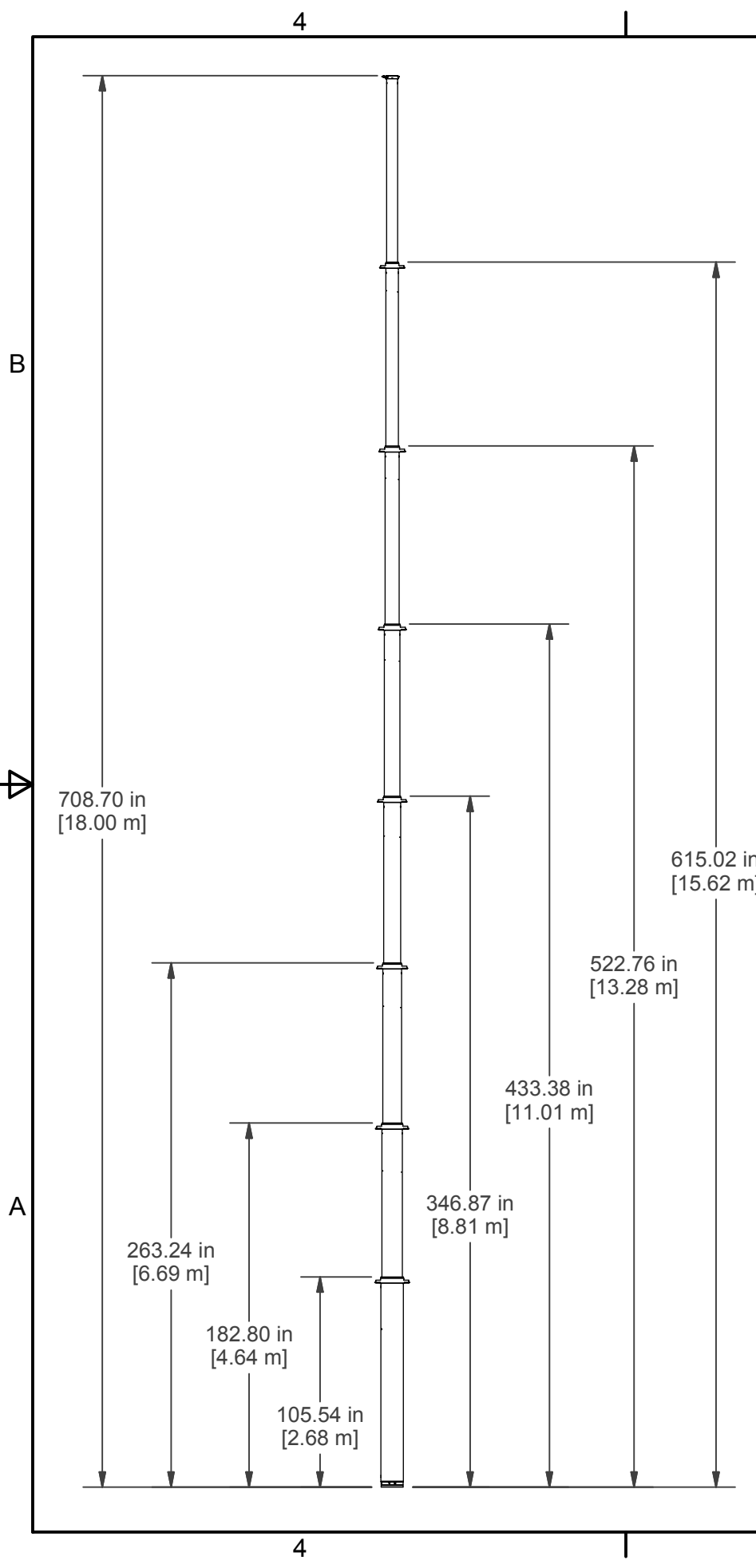

NOTES:

ALL DIMENSIONS ARE FOR REFERENCE ONLY.

LOCKING YOKES AND HARDWARE NOT SHOWN.

MAST SHOWN WITHOUT OPTIONAL ACCESSORIES.

MAST PAYLOAD LIFTING CAPACITY: 450 LB [205 kg]  
 APPROXIMATE MAST WEIGHT: 500 LB [227 kg]  
 NUMBER OF MAST SECTIONS: 8  
 TOP TUBE DIAMETER: Ø5.25 in [135 mm]  
 BASE TUBE DIAMETER: Ø11.25 in [288 mm]  
 EXTERNAL WIPERS: YES

<b>MATERIAL</b> ALUMINUM TUBES	UNLESS OTHERWISE SPECIFIED DIMENSIONS ARE IN INCHES. TOLERANCES ON DECIMALS    ANGLES 0 = ± 0.030                      ± 1/2° 00 = ± 0.010 000 = ± 0.005 FRACTIONAL ± 1/64"
<b>FINISH</b> BLACK HARDCOAT W/PDTE PER MIL-A-8625 TYPE III, CLASS 2	1. ALL INSIDE EDGES TO HAVE .005" TO .035" FILLETS. 2. ALL OUTSIDE EDGES TO HAVE .005" TO .015" CHAMFER OR RADIUS.
APPROX. WT: N/A	
<b>THIRD ANGLE PROJECTION</b>	125° ON ALL MACHINED SURFACES

<b>PROPRIETARY AND CONFIDENTIAL</b> THE INFORMATION CONTAINED IN THIS DRAWING IS THE SOLE PROPERTY OF THE WILL-BURT COMPANY ANY REPRODUCTION IN PART OR WHOLE WITHOUT THE WRITTEN PERMISSION OF THE WILL-BURT COMPANY IS PROHIBITED.	
APPROVALS	DATE
DRAWN AWASSON	6/29/2011
CHECKED	

<b>WILL-BURT</b> AN EMPLOYEE OWNED COMPANY ORRVILLE, OH	
TITLE <b>3.2M-18M SHDL PNEUMATIC MAST</b>	
SIZE B	DWG NO 710691830 INSTALL
PN: 710691830	REV 00
SHEET 1 OF 1	