



POSITION IT™

POSITIONIT RACK MOUNT CONTROLLER (P/N: 5340101) OPERATOR'S MANUAL



The Will-Burt Company
169 S. Main Street
Orrville, OH 44667

www.willburt.com

TP-5362301-B, July 2017
© 2017 The Will-Burt Company

Warranty

Will-Burt warrants its PositionIt Rack Mount Controller to be free from defects in material and workmanship for a period of two (2) years with such time periods running from the date of shipment by Will-Burt. Will-Burt shall not be responsible for any damage resulting to or caused by its products by reason of failure to properly install, maintain or store the product; use of the product in a manner inconsistent with its design; unauthorized service, alteration of products, neglect, abuse, accident, or acts of God. This warranty does not extend to any component parts not manufactured by Will-Burt; provided, however, Will-Burt's warranty herein shall not limit any warranties by manufacturers of component parts which extend to the buyer.

THE FOREGOING WARRANTY IS IN LIEU OF ALL OTHER WARRANTIES, AND NO REPRESENTATIONS, GUARANTEES OR WARRANTIES, EXPRESS OR IMPLIED, INCLUDING BUT NOT LIMITED TO, A WARRANTY OF MERCHANTABILITY, FITNESS FOR A PARTICULAR PURPOSE, OR NON-INFRINGEMENT ARE MADE BY WILL-BURT IN CONNECTION WITH THE MANUFACTURE OR SALE OF ITS PRODUCTS. NO EMPLOYEE, DISTRIBUTOR, OR REPRESENTATIVE IS AUTHORIZED TO CHANGE THIS WARRANTY IN ANY WAY OR GRANT ANY OTHER WARRANTY ON BEHALF OF WILL-BURT.

Claims for defects in material and workmanship shall be made in writing to Will-Burt within thirty (30) days of the discovery of defect. Failure to provide notice as required hereby shall be conclusive evidence that the product was in conformity with the warranty, and Will-Burt shall be released from any and all liability relating to the product. Will-Burt may either send a service representative or have the product returned to its factory at Buyer's expense for inspection. If judged by Will-Burt to be defective in material or workmanship, the product will be replaced or repaired at the option of Will-Burt, free from all charges except authorized transportation.

THE REMEDIES OF BUYER SET FORTH HEREIN ARE EXCLUSIVE AND ARE IN LIEU OF ALL OTHER REMEDIES. THE LIABILITY OF WILL-BURT WHETHER IN CONTRACT, TORT, UNDER ANY WARRANTY, OR OTHERWISE, SHALL NOT EXTEND BEYOND ITS OBLIGATION TO REPAIR OR REPLACE, AT ITS OPTION, ANY PRODUCT OR PART FOUND BY WILL-BURT TO BE DEFECTIVE IN MATERIAL OR WORKMANSHIP. WILL-BURT SHALL NOT BE LIABLE FOR COST OF INSTALLATION AND/OR REMOVAL, OR BE RESPONSIBLE FOR DIRECT, INDIRECT, SPECIAL OR CONSEQUENTIAL DAMAGES OF ANY NATURE.

Document History

Document Numbers	Dates	Remarks
TP-5362301-00	April 21, 2016	Initial Release
TP-5362301-A	June 19, 2017	Updated Table 2-1
TP-5362301-B	July 31, 2017	Added Figure 2-3. Updated to include the PositionIt PI-35.

Table of Contents

Section 1 Introduction	1-1
1.1 Safety Precautions	1-1
1.2 Manual Organization	1-1
1.3 Additional Documentation	1-1
1.4 Specifications	1-2
1.5 What's in the Box?	1-2
Section 2 Installation	2-1
2.1 Pre-Installation Check	2-1
2.2 Physical Installation.....	2-2
2.3 System Wiring	2-3
Section 3 Operation	3-1
3.1 Pre-Operation Check	3-1
3.2 Switching on the System.....	3-1
3.3 Manual Driving	3-2
3.4 Stowing and Unstowing the Positioner	3-2
3.5 Stow Confirmation	3-3
3.6 Setting Stow and Unstow Positions	3-3
3.7 Setting Pan and Tilt Electronic Limit Stops	3-4

Table of Figures

Figure 2-1 PositionIt Rack Mount Controller Dimensions	2-2
Figure 2-2 PositionIt Rack Mount Controller Connector Pinouts	2-3
Figure 2-3 PositionIt Rack Mount Controller Schematic	2-4
Figure 3-1 Front Panel of PositionIt Rack Mount Controller	3-1
Figure 3-2 Front Panel of PositionIt Rack Mount Controller	3-2
Figure 3-3 Front Panel of PositionIt Rack Mount Controller	3-2
Figure 3-4 Rear of PositionIt Rack Mount Controller	3-3
Figure 3-5 Front Panel of PositionIt Rack Mount Controller	3-3
Figure 3-6 Front Panel of PositionIt Rack Mount Controller	3-4
Figure 3-7 Front Panel of PositionIt Rack Mount Controller	3-4

Table of Tables

Table 1-1 PositionIt Rack Mount Controller Specifications	1-2
Table 2-1 PositionIt Rack Mount Controller Connector Pinouts	2-3

Safety Summary

This section describes safety information for the system. These are recommended precautions that personnel must understand and apply throughout installation, operation, maintenance, and troubleshooting. Be sure to read and understand the entire manual before performing any procedure outlined in this manual. Contact the Will-Burt Company with any questions before performing any procedure outlined in this manual.

Signal Word Definitions

WARNING

Warnings highlight an essential operating or maintenance procedure, practice, condition, statement, etc., which, if not strictly observed, could result in injury to, or death of, personnel or long-term health hazards.

CAUTION

Cautions highlight an essential operating or maintenance procedure, practice, condition, statement, etc., which, if not strictly observed, could result in damage to, or destruction of, equipment or loss of mission effectiveness.

Note: Notes highlight an essential operating or maintenance procedure, condition, or statement.

General Safety Instructions

The following are general safety precautions that are not related to any specific procedures. These are recommended precautions that personnel must understand and apply throughout installation, operation, maintenance, and troubleshooting. Additional precautions which apply to specific procedures and steps may be listed with the procedure or step to which they apply.

WARNING

Electrocution Hazard! Do not touch live wires. Make sure all power has been disconnected prior to performing installation or maintenance. Make certain that the area is free of overhead power lines and other unwanted sources of electricity. Do not operate the system during an electrical storm. Follow OSHA safety regulations when working near energized power lines. Be sure to allow sufficient clearance on all sides of the mast to allow for side sway. Death or serious injury could result if proper precautions are not performed.

WARNING

Shock Hazard! Hazardous voltages are present in this equipment and may also be present in any associated items. Observe general safety precautions for handling equipment using high voltage. Always disconnect power before performing repair or test operations. Contact with high voltage will result in death or serious injury.

WARNING

Resuscitation! Personnel working with or near high voltages should be familiar with modern methods of resuscitation. Such information may be obtained from the Bureau of Medicine and Surgery, United States Navy.

Section 1 Introduction

Review this manual in its entirety. Contact the Will-Burt Company with any questions before performing any procedure outlined in this manual.

The PositionIt Rack Mount Controller (P/N: 5340101) is designed to both control and power the PositionIt positioners. The Rack Mount Controller also offers the ability to integrate other controllers such as the default remote joystick controller (P/N: 5098901) or a closed contact controller.

The PositionIt Rack Mount Controller is designed to work with the:

- PositionIt PI-150
- PositionIt PI-75
- PositionIt PI-35

1.1 Safety Precautions

Refer to the Safety Summary for precautions to be observed while operating or servicing this equipment.

1.2 Manual Organization

This manual is organized into the following sections:

Section 1 Introduction

Section 2 Installation

Section 3 Operation

1.3 Additional Documentation

In addition to this manual (TP-5362301), see the operator's manual for the appropriate positioner as follows:

- *PositionIt PI-150 (P/N: 5061001) and PI-75 (P/N: 5191201) Operator's Manual (TP-5129001)*
- *PositionIt PI-35 (P/N: 5467801) Operator's Manual (TP-5406201)*

If necessary, contact The Will-Burt Company to obtain the operator's manual. During installation and operation, be sure to follow all appropriate precautions from the operator's manual.

1.4 Specifications

Table 1-1 lists specifications for the PositionIt Rack Mount Controller.

Table 1-1 PositionIt Rack Mount Controller Specifications

	Specification
Input Voltage	110 – 240 VAC, 50/60 hz
Output Data	RS485 (2 wire) Pelco D, 2400 Baud Rate
Weight	< 2.5 kg (5.5 lb.)
Operational Temperature Range	-20 to 50°C (-4 to 122°F)

1.5 What's in the Box?

The following items are included in the package:

- PositionIt Rack Mount Controller (P/N: 5340101)
- Mains Lead – IEC connector to wall socket
- Close Contact Connector Mating Half
- Positioner Plug Mating Half Connector
- Spare Fuse x 2
- Rack Mount Fixings Kit
- User Manual
- Pinout Sheet
- QA Documentation

It is important that you retain all these items for future use and reference, even if they are not used in the initial installation.

Section 2 Installation

This section describes the installation of the system and provides general procedures that must be followed to ensure a successful installation. Use care to follow all precautions while installing.

2.1 Pre-Installation Check

Before installing the system, ensure:

- That all appropriate precautions from the operator's manual (Section 1.3) are followed.
- That the following warnings are understood and followed:

⚠ WARNING

Safety Instruction – Read Manual! Before attempting any installation, ensure all installers have fully read and understood this manual.

⚠ WARNING

Safety Instruction – Electrical Hazard! The PositionIt Rack Mount Controller is a mains powered device and contains dangerous voltages inside.

⚠ WARNING

Safety Instruction – Installation! Ensure the complete system is safe and unable to move before any installation or maintenance work is carried out on, or around, this system.

⚠ WARNING

Safety Instruction – Qualified Engineers! All electrical and mechanical work must be carried out by a suitably qualified engineers.

2.2 Physical Installation

Figure 2-1 describes the physical dimensions of the PositionIt Rack Mount Controller in millimeters.

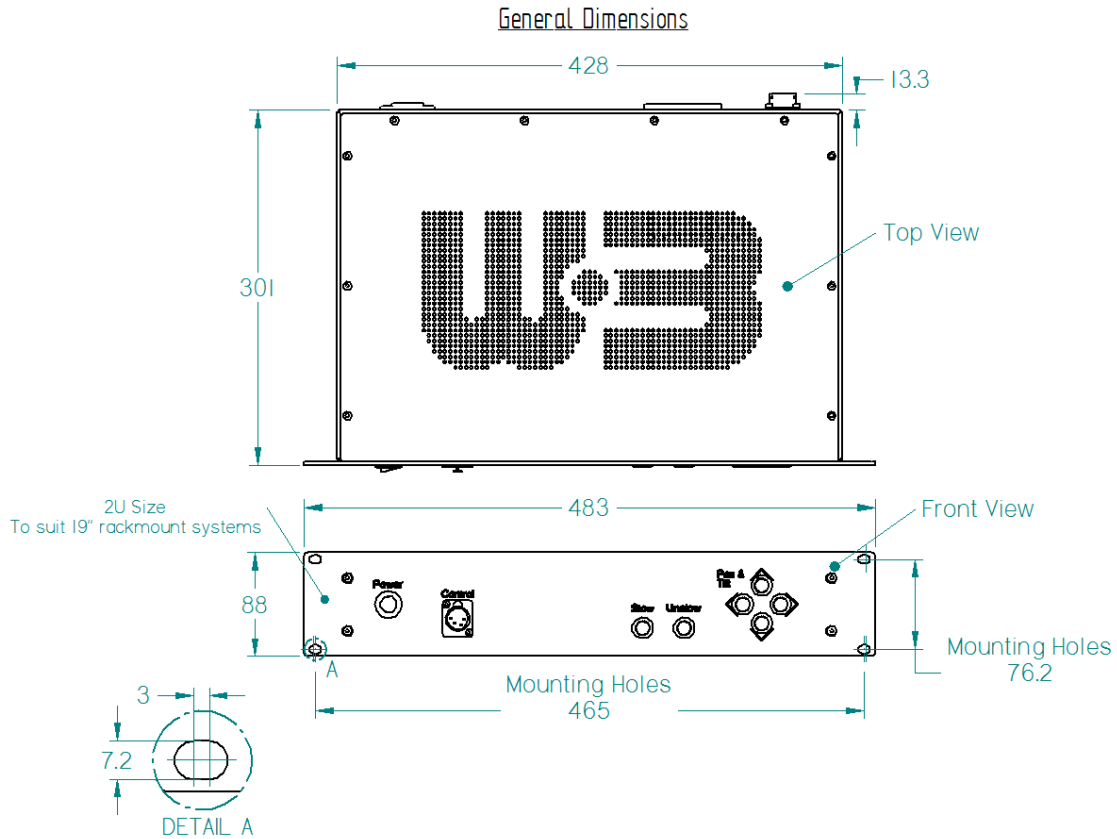

Figure 2-1 PositionIt Rack Mount Controller Dimensions

The PositionIt Rack Mount Controller is a 2U profile designed to suit a standard 482.6 (19 inch) rack mount. Included in the package is a fixings kit which is to be used to install the controller into a rack mount system.

2.3 System Wiring

Figure 2-2 and Table 2-1 describe the electrical pinout for the PositionIt Rack Mount Controller. Figure 2-3 shows the PositionIt Rack Mount Controller schematic.

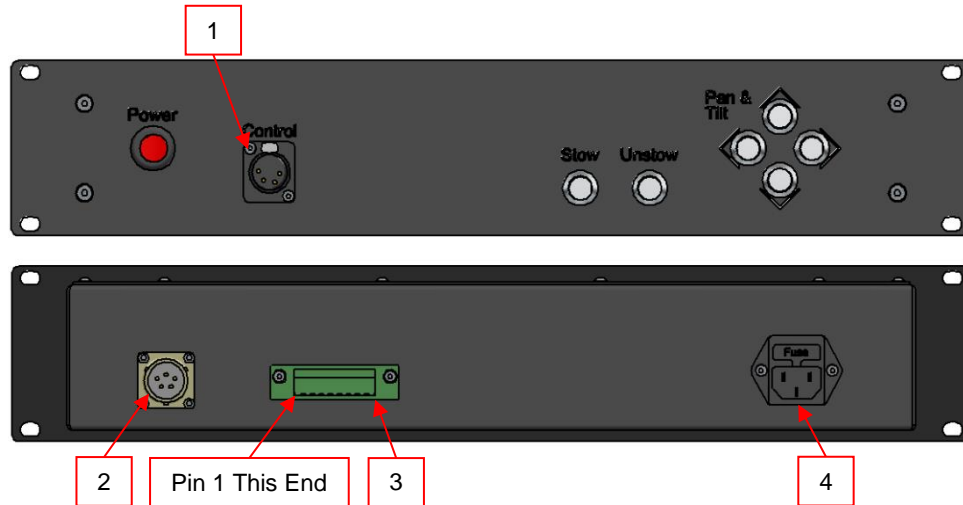

Figure 2-2 PositionIt Rack Mount Controller Connector Pinouts

Table 2-1 PositionIt Rack Mount Controller Connector Pinouts

1 - Control Plug	
Pin Number	Function
1	Data A
2	Data B
3	12 VDC
4	0 V

2 - Positioner Plug	
Pin Number	Function
A	Data A
B	Data B
C	+24 VDC
D	0 V
E	Chassis Gnd

3 - Contact Switch Connector	
Pin Number	Function
1	Power 24 VDC
2	Low When Stowed
3	Power 24 VDC (To Contacts)
4	Stow
5	Un-Stow
6	Pan CCW
7	Pan CW
8	Tilt Up
9	Tilt Down

4 – IEC Power Socket + Fuse Holder
Power 110 VAC – 240 VAC 50-60hz 2 Amp Max Current Fuse Type - 2 Amp - Quick Blow Spare fuses provided.

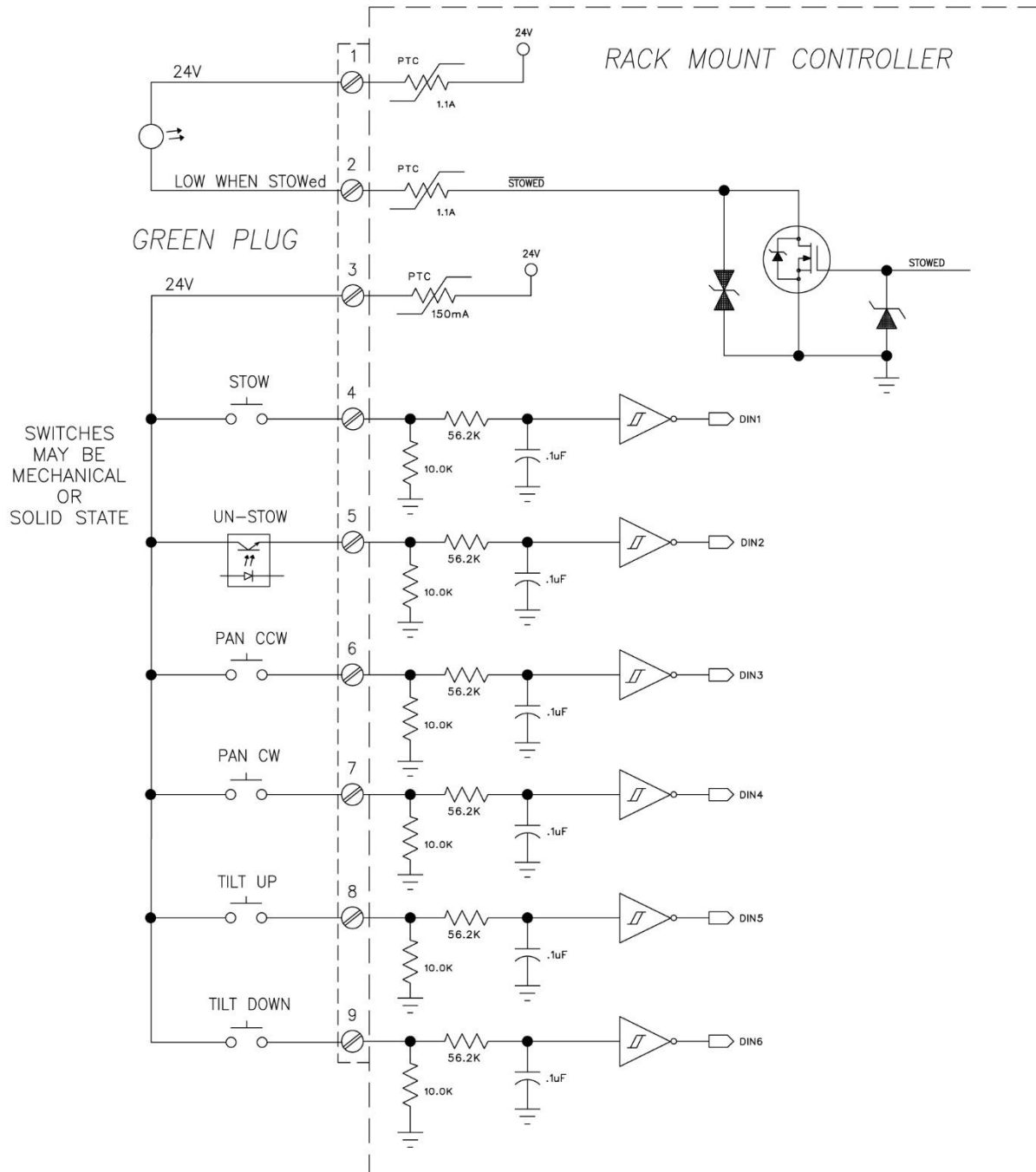

Figure 2-3 PositionIt Rack Mount Controller Schematic

Section 3 Operation

This section describes the operation of the system. Use care to follow all precautions while operating.

3.1 Pre-Operation Check

Before operating the system, ensure:

- That all appropriate precautions from the operator's manual (Section 1.3) are followed.
- Ensure that the following warnings are understood and followed:

⚠ WARNING

Safety Instruction – Installation! Ensure all aspects of the installation have been carried out correctly and are safe before attempting to operate the system.

⚠ WARNING

Safety Instruction – Operation! Before moving the PositionIt positioner the operator must first make sure it is safe to do so.

3.2 Switching on the System

The illuminated Power Rocker Switch (Figure 3-1) on the front panel of the Rack Mount controls both the power for the Rack Mount Controller and also to the positioner.

Once switched on, wait for (10) seconds before attempting any control inputs. This will allow the system to initialize fully.



Figure 3-1 Front Panel of PositionIt Rack Mount Controller

3.3 Manual Driving

The PositionIt system can be manually driven using the (4) arrowed buttons labelled Pan and Tilt on the front panel (Figure 3-2). These are non-latching push-button controls. To move the positioner, push and hold the related direction button and release when the desired position is reached.

The driving speed of the positioner is proportional. When using the Pan and Tilt buttons it will start slow then ramp up to its maximum over a couple of seconds. Use quick momentary button presses to achieve accurate small movements.

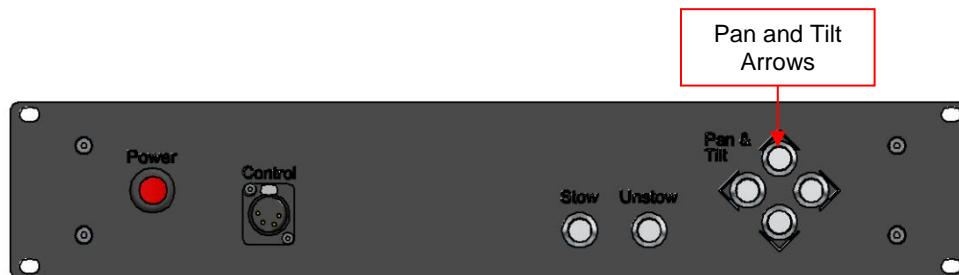

Figure 3-2 Front Panel of PositionIt Rack Mount Controller

3.4 Stowing and Unstowing the Positioner

To Stow the positioner, simply momentarily press the button labelled “Stow” on the front panel of the Rack Mount Controller (Figure 3-3). The unit will drive itself to the pre-programmed stow position.

To unstow the positioner simply momentarily press the button labelled “Unstow” on the front panel of the Rack Mount Controller (Figure 3-3). The unit will drive itself to the pre-programmed Unstow position.

If any other control inputs are sent to the positioner before either the Stow or Unstow actions are complete these will interrupt the process. This will stop the positioner from finishing the stow or unstow process.

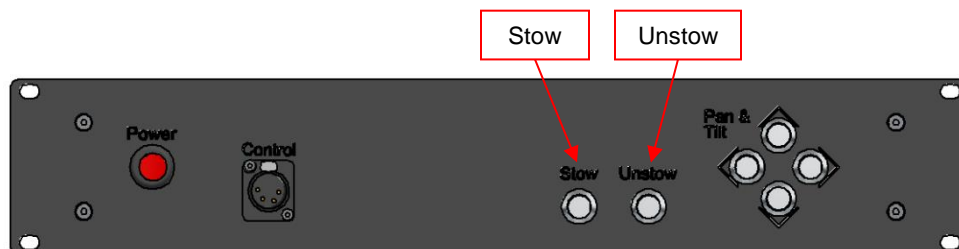

Figure 3-3 Front Panel of PositionIt Rack Mount Controller

3.5 Stow Confirmation

A stow confirmation signal is provided on the rear of the unit through the Phoenix connector (Figure 3-4). This is provided on Pin 8 as a switched ground.



Figure 3-4 Rear of PositionIt Rack Mount Controller

Once a stow command is sent, the positioner will move to its pre-programmed stow position. Once this stow position is reached and the positioner has fully stopped this ground on pin 8 will become active.

Any further input to the positioner will cancel this and the ground will be removed.

Note: This stow confirmation function will not work if the stow command is sent from the Joystick Control. The unit will stow but no confirmation signal will be shown.

3.6 Setting Stow and Unstow Positions

The Stow and Unstow positions on the positioners can be programmed through the Rack Mount Controller.

To set the Stow position:

1. Manually drive the positioner into the position required for stowing
2. Press and hold the Pan and Tilt “Left” and “Right” buttons at the same time, then, press the “Stow” button and hold all three for (3) seconds (Figure 3-5).

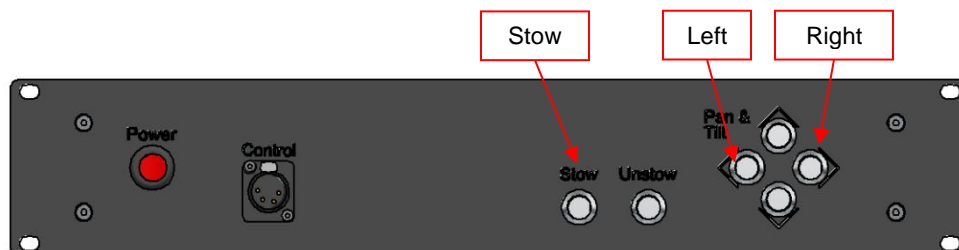

Figure 3-5 Front Panel of PositionIt Rack Mount Controller

3. The stow position is now set.

It is advised that the Stow position is tested after being set to ensure it been programmed correctly.

To set the Unstow Position:

1. Manually drive the positioner into the position required for unstowing
2. Press and hold the Pan and Tilt “Left” and “Right” buttons at the same time, then, press the “Unstow” button and hold all three for (3) seconds (Figure 3-6).

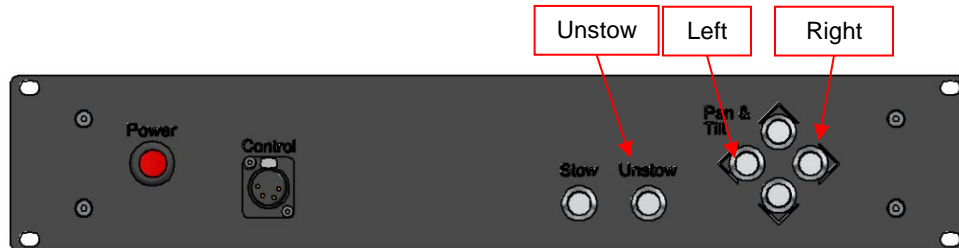

Figure 3-6 Front Panel of PositionIt Rack Mount Controller

3. The unstow position is now set.

It is advised that the Unstow position is tested after being set to ensure it been programmed correctly.

3.7 Setting Pan and Tilt Electronic Limit Stops

The positioner uses electronic limit stops. The positioner does not have mechanical hard stops. The positioner comes from the factory with electronic limit stops set to the maximum recommended pan and tilt. The limit stops can be adjusted through the controller, but it is not possible to remove the limit stops completely.

To set the electronic limit stops:

1. Connect the default joystick controller (P/N: 5098901) to the control connector (Figure 3-7).

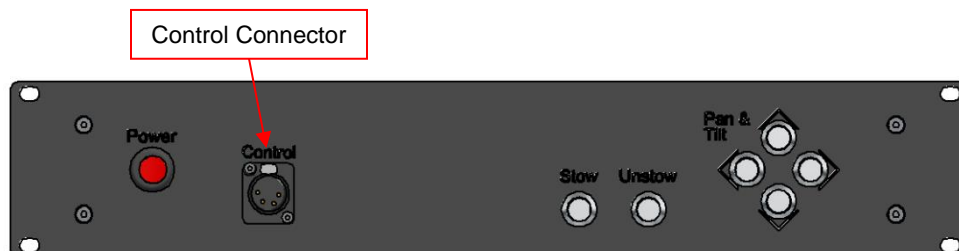

Figure 3-7 Front Panel of PositionIt Rack Mount Controller

2. Set the electronic limit stops according to the operator’s manual (Section 1.3).
3. Remove the default joystick controller.
4. Verify the electronic limit stops.